

## Worm Gear Screw Jacks

Reliable and versatile high performance screw jacks



*Linear Motion. **Optimized.***<sup>™</sup>

## Thomson – the Choice for Optimized Motion Solutions

Often the ideal design solution is not about finding the fastest, sturdiest, most accurate or even the least expensive option. Rather, the ideal solution is the optimal balance of performance, life and cost.

### **The Best Positioned Supplier of Mechanical Motion Technology**

Thomson has several advantages that make us the supplier of choice for motion control technology.

- Thomson owns the broadest standard product offering of mechanical motion technologies in the industry.
- Modified versions of standard product or white sheet design solutions are routine for us.
- Choose Thomson and gain access to over 70 years of global application experience in industries including packaging, factory automation, material handling, medical, clean energy, printing, automotive, machine tool, aerospace and defense.

### **A Name You Can Trust**

A wealth of product and application information as well as 3D models, software tools, our distributor locator and global contact information is available at [www.thomsonlinear.com](http://www.thomsonlinear.com). For assistance in Europe, contact us at +44 1271 334 500 or e-mail us at [sales.europe@thomsonlinear.com](mailto:sales.europe@thomsonlinear.com).

Talk to us early in the design process to see how Thomson can help identify the optimal balance of performance, life and cost for your next application. And, call us or any of our 2000+ distribution partners around the world for fast delivery of replacement parts.

### **Local Support Around the Globe**

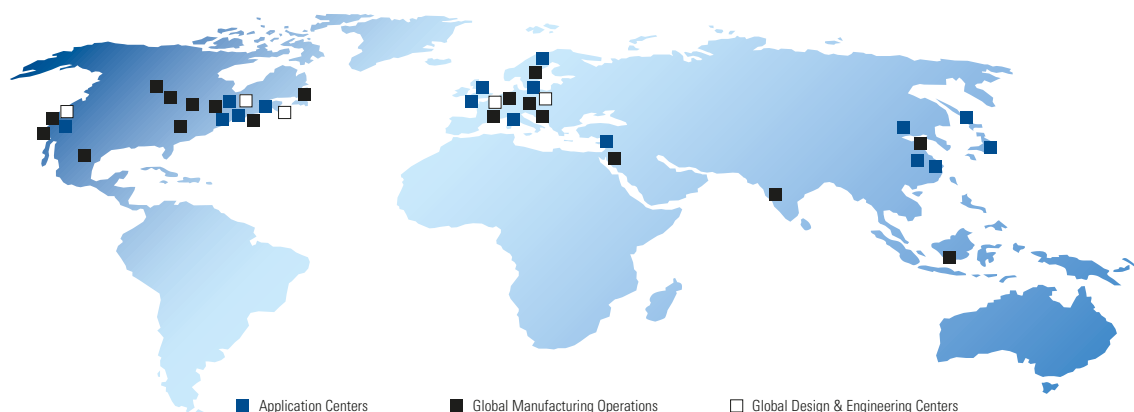

# Table of contents

<b>Worm gear screw jack applications</b> .....	<b>4</b>	<b>Accessories</b> .....	<b>38</b>
<b>The Thomson screw jack range</b> .....	<b>5</b>	Top plate BP .....	38
<b>Selection chart</b> .....	<b>6</b>	Fork end GA.....	39
<b>Presentation of the MULI® and JUMBO® series</b> .....	<b>9</b>	Clevis end GK.....	39
Design versions.....	10	Protection Bellow F.....	40
General technical data.....	12	Adapter for attaching a second bellow .....	42
<b>Sizing and selection</b> .....	<b>15</b>	Spiral spring band cover SF.....	42
Worm gear screw jack and drive unit selection.....	16	Trapezoidal bronze nut TGM-EFM.....	44
Critical buckling force calculations.....	17	Flanged ball nut KGF-N.....	45
Critical speed calculations.....	18	Flanged ball nut KGF-D .....	46
Drive torque and holding moment calculations.....	20	Universal joint adapter KAR .....	47
Lifetime, force and torque considerations.....	21	Adapter bracket KON .....	48
Performance tables .....	24	Mounting feet L.....	49
<b>Order code</b> .....	<b>28</b>	Universal joint adapter K, KZP, KB,KBP .....	50
Checklist.....	29	Bearing units AFF for screw end.....	51
Screw jack system configurations .....	33	Bearing units BF for screw end.....	52
<b>Dimensions</b> .....	<b>34</b>	Handwheels HR.....	53
Version N and V .....	34	Safety nut SFM with wear indicator .....	54
Version R .....	36	Limit switch with roller lever ES .....	56
		<b>Drive technology</b> .....	<b>58</b>
		3-phase motors DRS / DRE.....	59
		Servo motors AKM.....	61
		Motor adapter flanges MG for 3-phase motors.....	63
		Couplings.....	65
		Joint shafts VWK.....	70
		Pillow block bearing UKP.....	74
		Intermediate shaft pin WZK .....	74
		Joint shafts VW .....	75
		Joint shafts GX.....	76
		Clamping units .....	77
		Bevel gear boxes KRG.....	78
		<b>Installation and Maintenance</b> .....	<b>82</b>

## Worm Gear Screw Jack Applications

Worm gear screw jacks are ideal for various applications, regardless if you are lifting, lowering, tipping or moving. In each case, the different industries and the different power parameters require a powerful, reliable screw jack that is easy to adapt to the specific application, and to extend to a complete worm gear screw jack system.

Scissor-lift system



Four screw jacks in different configurations driven by a single motor

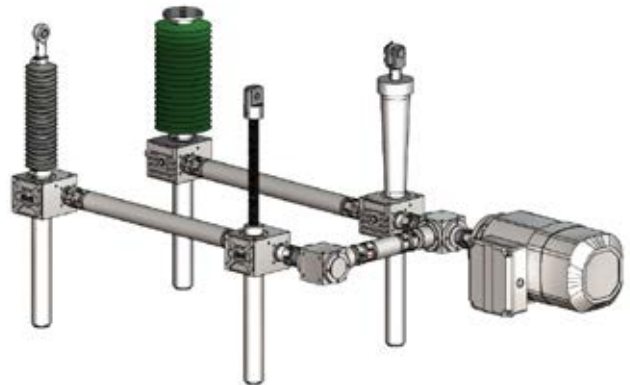

Lifting device for an automatic bar-machining installation

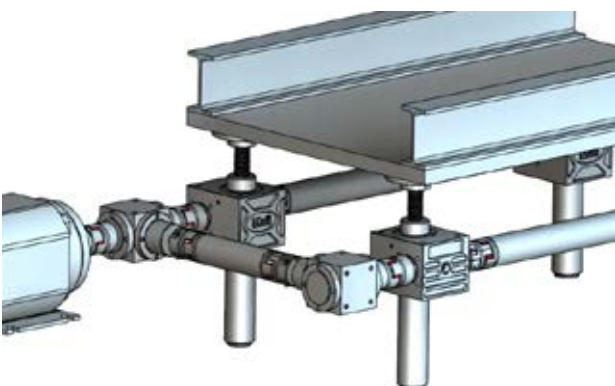

## The Thomson Screw Jack Range

The Thomson MULI<sup>®</sup> and JUMBO<sup>®</sup> series worm gear screw jacks provide reliability in use and versatility in application. With its easy-to-mount, cubic housing, it can easily be extended to form wide-area jack systems with the help of its wide range of accessories. Thomson screw jacks are designed around a precision trapezoidal or ball screw drive engineered from Thomson for high accuracy and performance.

- The large product range offers a variety of worm gear screw jack designs and sizes. Heavy loads can be handled and high speeds can be achieved.
- The use of high quality materials and a modern manufacturing process ensures that Thomson screw jacks will be a reliable precision component in your machine.
- We offer complete calculation and sizing up to complete screw jack systems including drive technology. You save time-consuming choice of many single components.



# Worm Gear Screw Jack Selection Chart

**MULI<sup>®</sup> 0 - 5**  
(– 100 kN)

## Axially travelling screw

The rotary motion of precision worm gearing (worm shaft and internally threaded worm wheel) is converted into axial linear motion of the screw, which travels through the gear box housing. The load is attached to the end of the screw.

**N/V-TGS**  
**N-KGS**

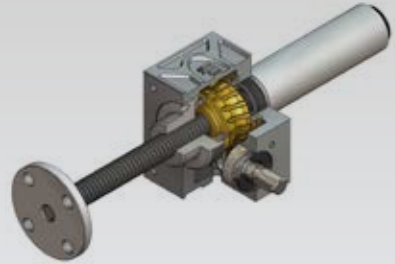

**V-KGS**

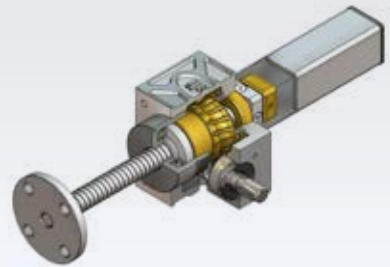

**JUMBO<sup>®</sup> 1 - 5**  
(– 500 kN)

## Rotating screw

Driven by a precision worm gearing (screw keyed to the worm wheel), the rotary motion of the screw is translated into linear motion of the travelling nut on the screw.

**R-TGS/KGS**

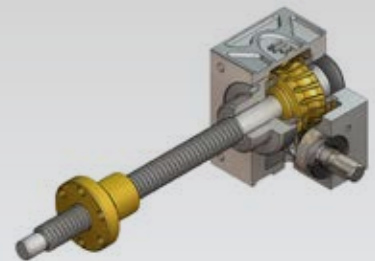

# Worm Gear Screw Jack Selection Chart

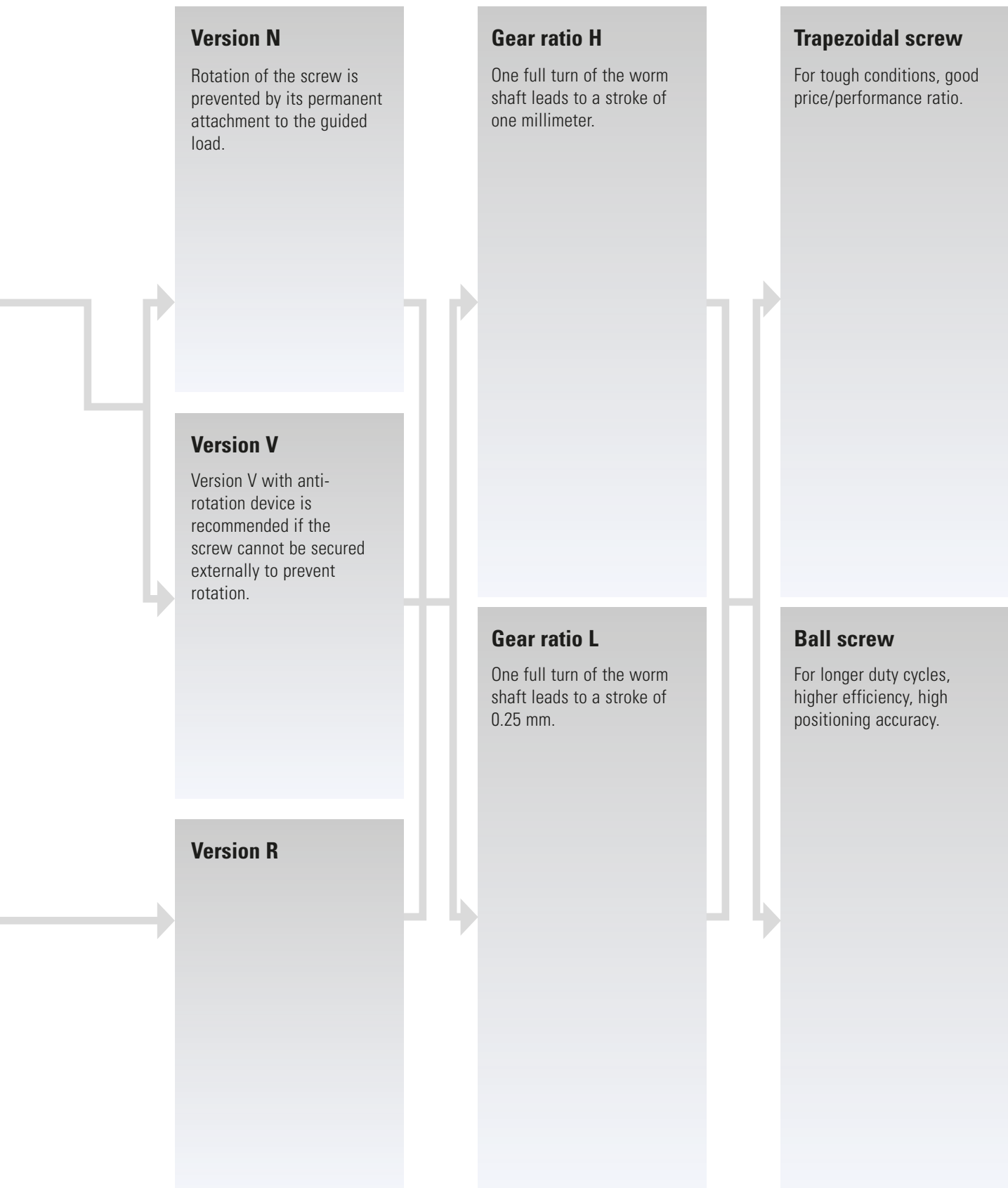



Surveying axles for rod locomotives, Hörmann Railway Technology, Germany



## Presentation of the MULI<sup>®</sup> and JUMBO<sup>®</sup> Series

Thomson worm gear screw jacks of the MULI<sup>®</sup> and JUMBO<sup>®</sup> series are manufactured for loads from 2.5 to 500 kN. All models are designed for both pushing and pulling forces, and for position-independent functioning. The cubic housing, standardised mounting material and end-pieces, and pre-drilled flange holes permit the ideal installation of motor, gears and shaft encoder. Synchronisation of several worm gear screw jacks is simple with the complete range of accessories.

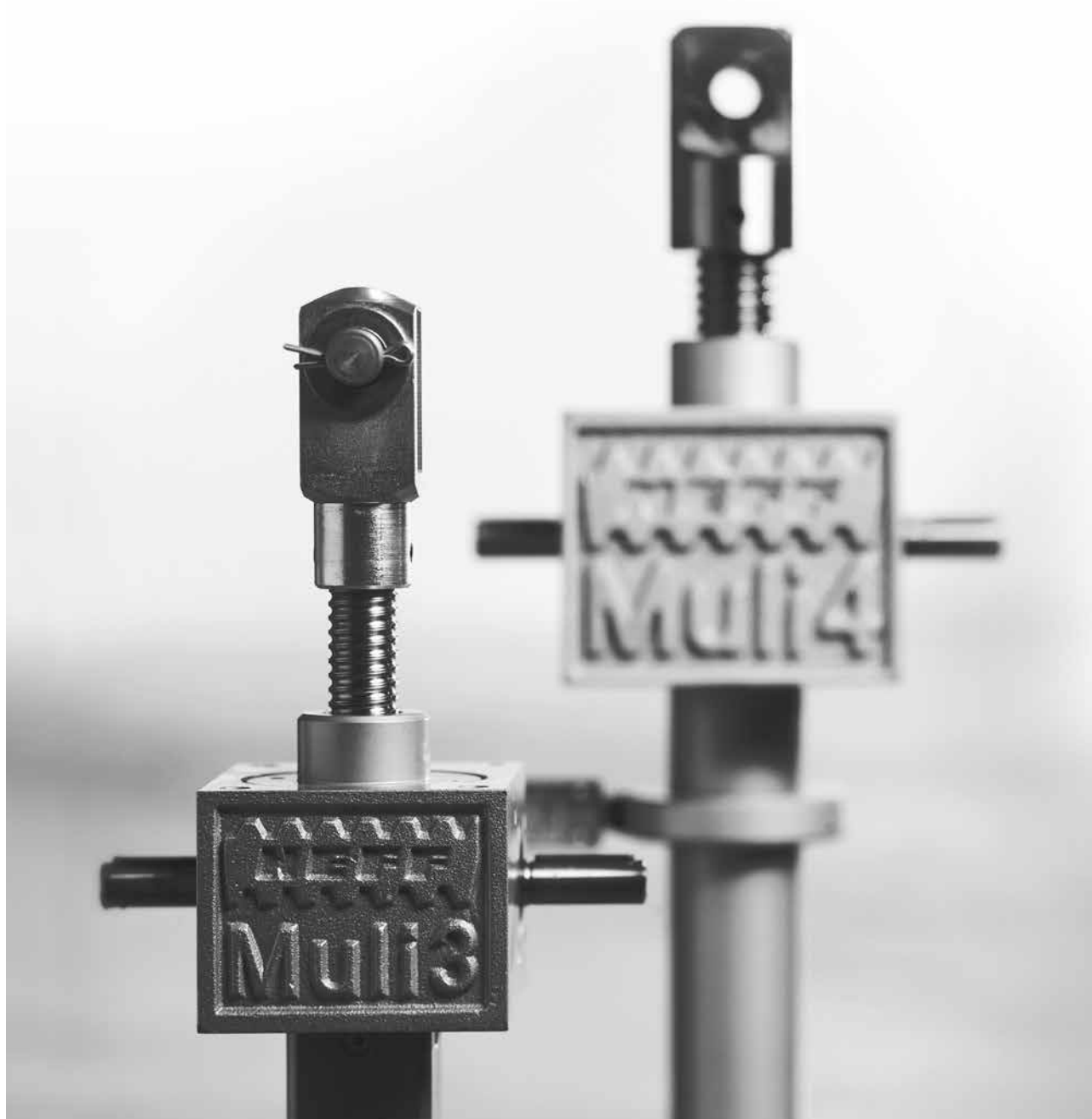

## Design Versions

### Axially travelling screw - version N or V

The rotary motion of precision worm gearing (worm shaft and internally threaded worm wheel) is converted into axial linear motion of the screw, which travels through the gear box housing. The load is attached to the end of the screw.

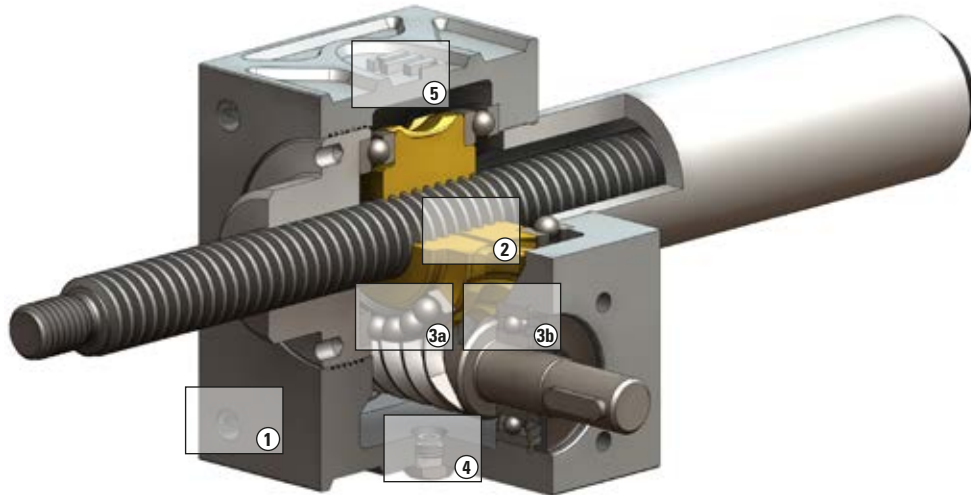

#### Functional Design

The cubic housing with its pre-drilled flange holes offers simple mounting, and allows longer power-on times. Longer lubricant lifetimes are ensured, because heat is more efficiently dissipated.

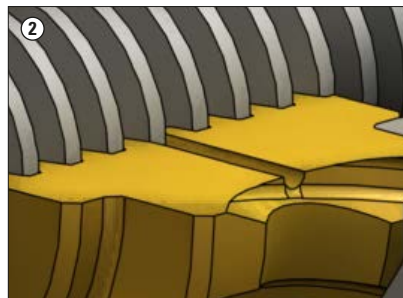

#### Lubrication of the Worm Wheel

Radial lubrication holes in the worm wheel grease the trapezoidal screw. The resultant lower friction and warming lead to an increased lifetime, especially in the case of longer strokes.

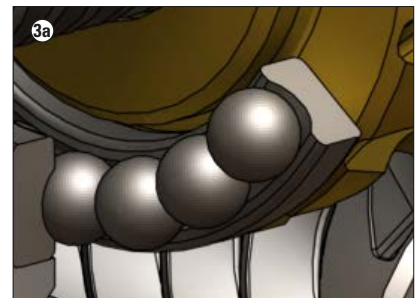

#### Heavy Duty Bearings

Axial ball bearings as the main pressure bearings (for all sizes) give a large safety margin, and increase the overall lifetime.

## Design Versions

### Rotating screw - version R

Driven by a precision worm gearing (worm shaft and worm wheel), the rotary motion of the screw is translated into linear motion of the travelling nut on the screw.

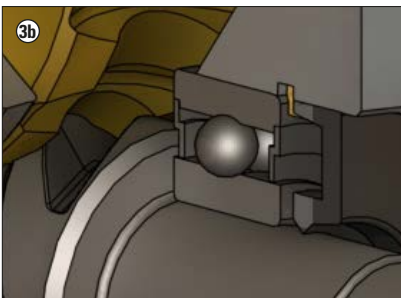
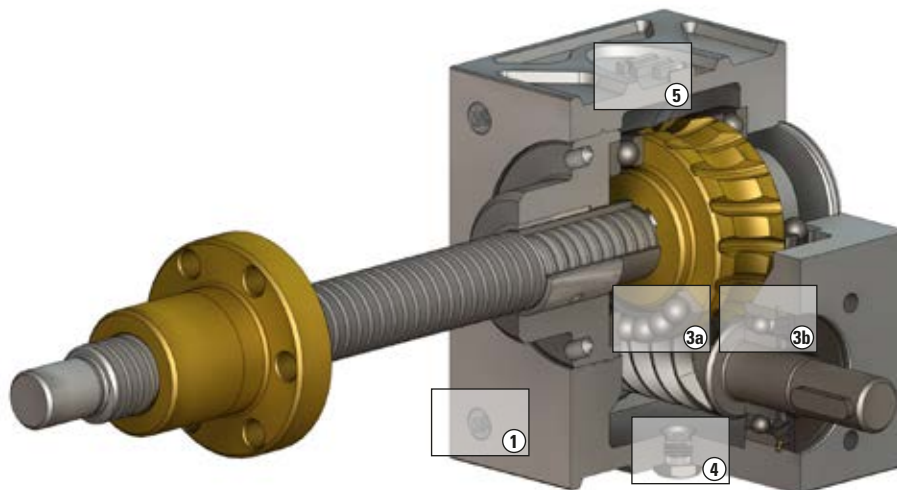

#### Heavy Duty Bearings

Radial deep-groove ball bearings (Muli<sup>®</sup> 0 – 3) and conical roller bearings (Muli<sup>®</sup> 4 + 5 and JUMBO<sup>®</sup> 1 – 5) on the worm shaft make it possible to handle heavy loads.



#### Lubrication

The worm gear screw jack is conveniently lubricated at one point. Maintenance – whether manual or automatic – is easy.

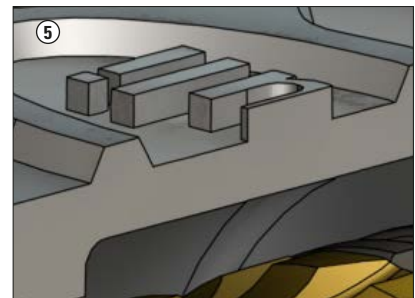

#### Housing Material

The housing in aluminium (Muli<sup>®</sup> 0 – 2) or highly stable spherical graphite cast iron (Muli<sup>®</sup> 3 and higher) provides more stability, especially at higher temperatures. This provides a safety margin, even under rugged conditions.

## General Technical Data

The range includes a total of 11 worm gear screw jack models in two series: MULI<sup>®</sup> 0 to MULI<sup>®</sup> 5 with lifting capacities up to 100 kN and JUMBO<sup>®</sup> 1 to JUMBO<sup>®</sup> 5 with lifting capacities from 150 kN to 500 kN statically.

### Speed of travel - gear ratio H (high speed)

Worm gear screw jacks with trapezoidal screw produce an advance of 1 mm for each revolution of the worm shaft. The linear speed is 1500 mm per min at 1500 RPM. Worm gear screw jacks with ball screws achieve between 1071 mm per min and 2124 mm per min, depending on size and lead.

### Speed of travel - gear ratio L (low speed)

Worm gear screw jacks with trapezoidal screw produce an advance of 0.25 mm for each full revolution of the worm shaft. That is, the linear speed is 375 mm per min at 1500 RPM. Worm gear screw jacks with ball screws achieve between 312 mm per min and 535 mm per min, depending on size and lead.

Please note that higher speeds of travel can be achieved with larger screw pitches or multiple start screws.

The worm gear screw jack's maximum drive revs



(standard grease lubrication) of 1500 RPM must not be exceeded.

The higher efficiency of the ball screw drive also permits a longer duty cycle.

### Tolerances and backlash

The gearbox housings are machined on the four mounting sides. The tolerances conform to DIN ISO 2768-mH. The sides C and D that are not machined conform to DIN 1688-T1/GTA 16 for MULI 0–2 as well as DIN 1685, GTB 18–GGG-40 from MULI 3.

The axial backlash of the jack screw under alternating load is as follows:

- Trapezoidal screws: up to 0.4 mm (to DIN 103)
- Ball screws: 0.08 mm.

The lateral play between the outside diameter of the screw and the guide diameter is 0.2 mm.

The backlash in the worm gears is  $\pm 4^\circ$  for gear ratio L and  $\pm 1^\circ$  for gear ratio H based on the drive shaft.

Trapezoidal screws are manufactured to a straightness of 0.3 – 1.5 mm/m, ball screws to a straightness of 0.08 mm/m over a length of 1000 mm and to the following pitch accuracies:

- MULI 0–MULI 5: 0.05 mm/300 mm length
- JUMBO 1–JUMBO 5: 0.2 mm/300 mm length.

### Lateral forces on the jack screw.

Any lateral forces that may occur should be taken by an external guide rail.

## General Technical Data

### Stop collar A

Prevents the screw from being removed from the jack gearbox. Fitted as standard on ball screw versions N and V. Optionally available for screw jacks with trapezoidal screws. The stop collar cannot be used as a fixed stop.

### Self-locking

The self-locking function depends on a variety of parameters:

- Large pitches
- Different gear ratios
- Lubrication
- Friction parameters
- Ambient influences, such as high or low temperatures, vibrations, etc.
- The mounting position

Versions with ball screw and TGS/KGS with large pitches are consequently not self-locking. Suitable brakes or braking motors must therefore be considered in such cases. Limited self-locking can be assumed for smaller pitches (single-start).

### Special versions

In addition to the extensive standard range, anti-clockwise, multi-start and special material worm gear screw jacks can be supplied upon request.

Surfaces are basic coated starting from size Multi<sup>®</sup> 3. Upon request the following surface treatments are available:

- electroless nickel plating
- stainless steel for selected parts
- epoxy-colour-coated with 2 top layer surfaces (according to RAL)
- ATC-coated ball screws and ball screw nuts

Please ask our product specialists.



## General Technical Data

Trapezoidal screw													
			MULI 0	MULI 1	MULI 2	MULI 3	MULI 4	MULI 5	JUMBO 1	JUMBO 2	JUMBO 3	JUMBO 4	JUMBO 5
Maximum static lifting capacity <sup>1)</sup>	[kN]		2,5	5	10	25	50	100	150	200	250	350	500
Diameter x pitch	[mm]		14x4	18x4	20x4	30x6	40x7	55x9	60x9	70x10	80x10	100x10	120x14
Stroke per full turn of the drive shaft	[mm]	ratio H <sup>2)</sup>	1	1	1	1	1	1	1	1	1	1	1
		ratio L <sup>2)</sup>	0,25	0,25	0,25	0,25	0,25	0,25	0,25	0,25	0,25	0,25	0,25
Gear ratio		ratio H <sup>2)</sup>	4:1	4:1	4:1	6:1	7:1	9:1	9:1	10:1	10:1	10:1	14:1
		ratio L <sup>2)</sup>	16:1	16:1	16:1	24:1	28:1	36:1	36:1	40:1	40:1	40:1	56:1
Efficiency <sup>3)</sup>	[%]	ratio H <sup>2)</sup>	35	31	29	29	26	24	23	22	20	19	19
		ratio L <sup>2)</sup>	27	25	23	23	21	19	18	17	15	15	15
Weight (zero stroke)	[kg]		0,60	1,20	2,10	6,00	17,00	32,00	41,00	57,00	57,00	85,00	160,00
Weight per 100 mm stroke	[kg]		0,10	0,26	0,42	1,14	1,67	3,04	3,10	4,45	6,13	7,90	11,50
Idling torque	[Nm]	ratio H <sup>2)</sup>	0,02	0,04	0,11	0,15	0,35	0,84	0,88	1,28	1,32	1,62	1,98
		ratio L <sup>2)</sup>	0,016	0,03	0,10	0,12	0,25	0,51	0,57	0,92	0,97	1,10	1,42
Housing material			G – AL				EN – GJS						

Ball screw										
			MULI 0	MULI 1	MULI 2	MULI 3	MULI 4		MULI 5	JUMBO 3
Maximum static lifting capacity <sup>1)</sup>	[kN]		2,5	5	10	12,5	22	42	65	78
Diameter x pitch	[mm]		1205	1605	2005	2505	4005	4010	5010	8010
Dynamic load rating KGF – KGM	[kN]		2,5	5	10	12,2	23,8	38	68,7	86,2
Stroke per full turn of the drive shaft	[mm]	ratio H <sup>2)</sup>	1,25	1,25	1,25	0,83	0,71	1,43	1,1	1
		ratio L <sup>2)</sup>	0,31	0,31	0,31	0,21	0,18	0,36	0,28	0,25
Gear ratio		ratio H <sup>2)</sup>	4:1	4:1	4:1	6:1	7:1		9:1	10:1
		ratio L <sup>2)</sup>	16:1	16:1	16:1	24:1	28:1		36:1	40:1
Efficiency <sup>3)</sup>	[%]	ratio H <sup>2)</sup>	60	57	56	55	53	56	47	45
		ratio L <sup>2)</sup>	48	46	44	43	43	45	37	34
Weight (zero stroke)	[kg]		0,60	1,30	2,30	7,00	19,00		35,00	63,00
Weight per 100 mm stroke	[kg]		0,09	0,26	0,42	1,14	1,67		3,04	6,13
Idling torque	[Nm]	ratio H <sup>2)</sup>	0,02	0,04	0,11	0,15	0,35		0,84	1,32
		ratio L <sup>2)</sup>	0,016	0,03	0,10	0,12	0,25		0,51	0,97
Housing material			G – AL				EN – GJS			

1) Depending on travel speed, duty-cycle, etc.

2) H = high travel speed

2) L = low travel speed

3) The specified efficiency values are average values.

Note: Initial breakaway torque: approx. 2-3 times nominal torque in run-up (Frequency inverter control!)

## Sizing and Selection

The procedure for planning screw jack systems is generally as follows:

1. Definition of the speed and possible mounting positions of the worm gear screw jacks.
2. Selection of the drive components (couplings, shafts, bevel gearboxes, motors) for synchronous drive of the individual worm gear screw jacks. The following criteria are decisive:
  - Lowest possible loading of the individual transmission components. Input of the entire drive torque via the teeth of a bevel gearbox must be avoided in particular.
  - As few transmission components as possible and short joint shafts.

- Provision for the use of a torque-limiting coupling to protect the system. It is sometimes difficult to show the direction of rotation of the individual components in the drawing. The following method can generally be used:
  - Define the position of the individual worm gear screw jacks.
  - Enter the direction of rotation of each worm gear screw jack for the “lifting” motion (the direction of rotation of a shaft is shown by an arrow pointing in the direction of movement of a point on the upper side of the shaft).
  - Draw in the possible position of the bevel gear boxes.
  - Determine the direction of rotation and position of the bevel gear.



## Worm Gear Screw Jack and Drive Unit Selection

After selecting the drive unit, it is important to check whether the worm gear screw jack or any transmission components may be overloaded by the drive unit. The following points should also be established:

1. On which side is the motor to be mounted.
2. Direction of rotation of the jack systems.

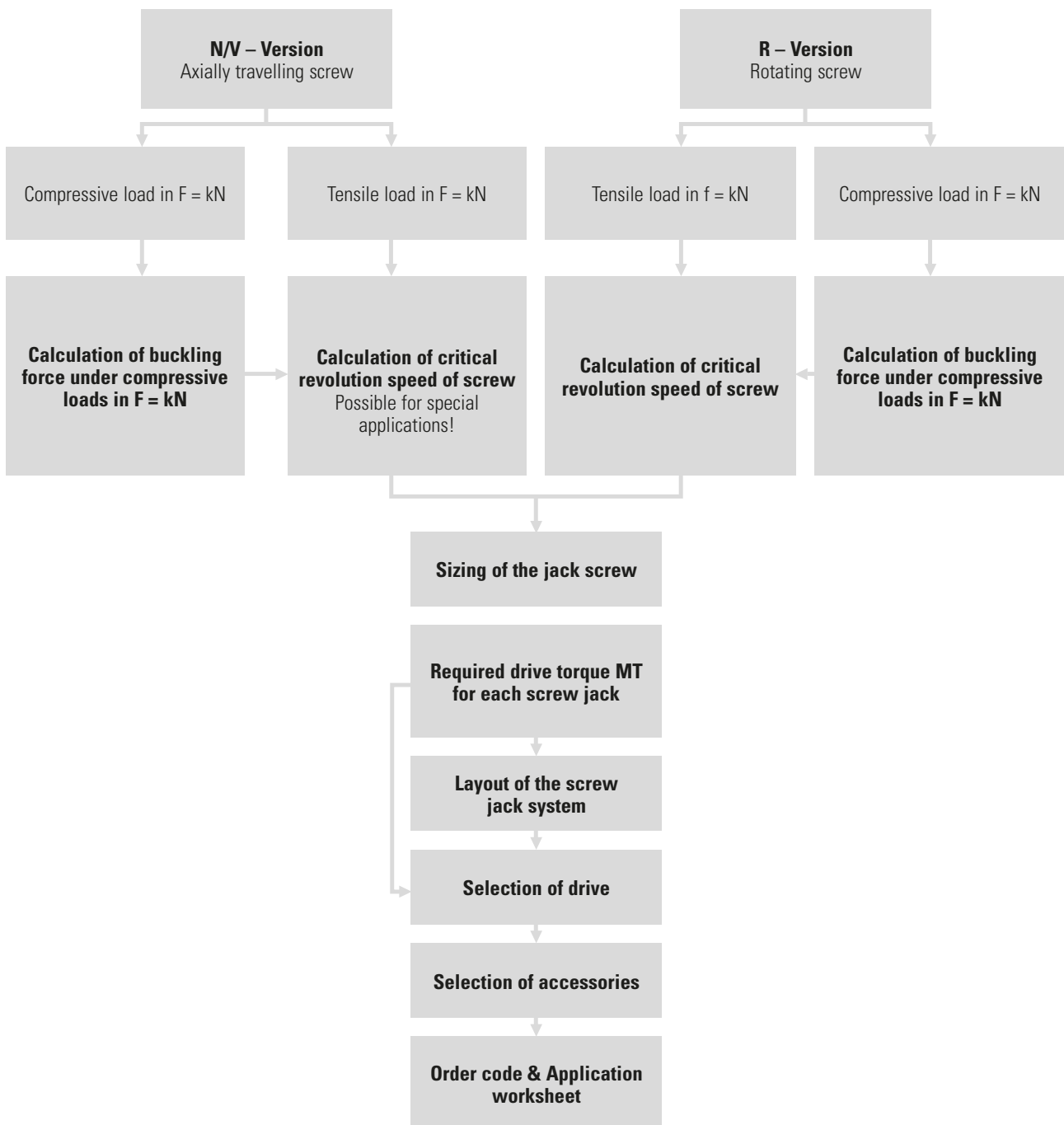



# Critical Buckling Force Calculations

Thin lifting screws may buckle sideways when subjected to compressive loads. Before the permissible compressive force is defined for the screw, allowance must be made for safety factors as appropriate to the installation.

$$F_{zul} = f_k \cdot F_{krit} \cdot 0,8$$

- $F_{zul}$  Max. allowable axial force [kN].
- $f_k$  Correction factor that considers the type of screw jack bearing.
- $F_{krit}$  Theoretical critical buckling force as a function of the unsupported length L [kN].
- 0,8 Safety factor  $C_K$

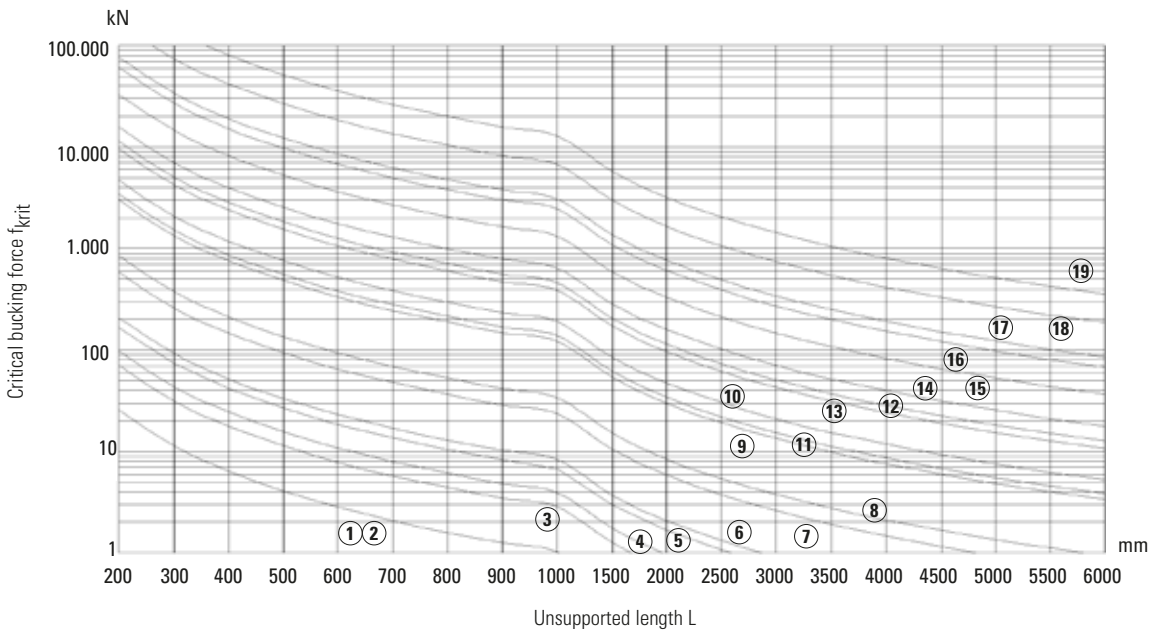

- |                   |                   |                    |                     |
|-------------------|-------------------|--------------------|---------------------|
| ① Muli0 – KGS1205 | ⑥ Muli2 – KGS2005 | ⑪ Muli4 – KGS4010  | ⑯ Jumbo3 – Tr80x10  |
| ② Tr14x4          | ⑦ Muli3 – KGS2505 | ⑫ Muli5 – Tr55x9   | ⑰ KGS8010           |
| ③ Muli1 – KGS1605 | ⑧ Tr30x6          | ⑬ KGS5010          | ⑱ Jumbo4 – Tr100x10 |
| ④ Tr18x4          | ⑨ Muli4 – Tr40x7  | ⑭ Jumbo1 – Tr60x9  | ⑲ Jumbo5 – Tr120x14 |
| ⑤ Muli2 – Tr20x4  | ⑩ KGS4005         | ⑮ Jumbo2 – Tr70x10 |                     |

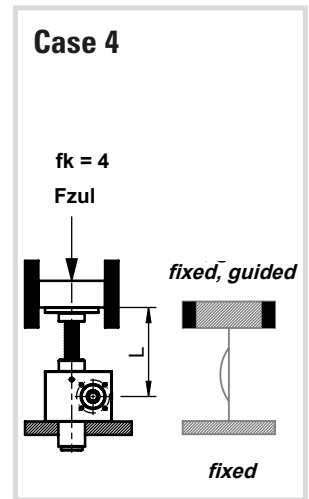
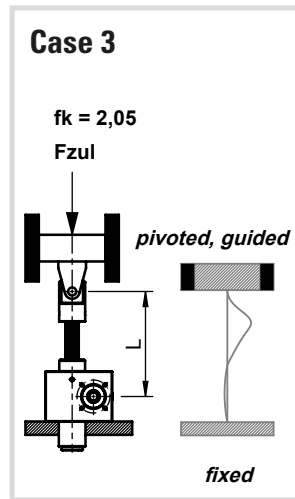
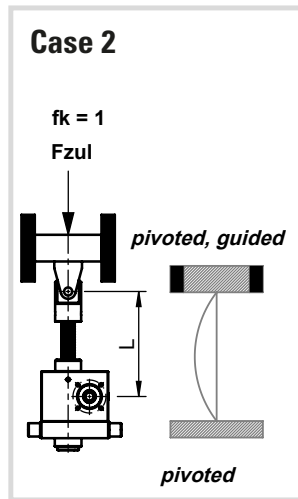
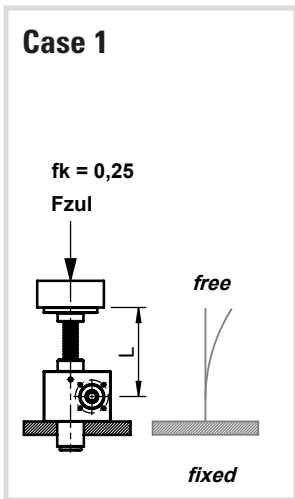

# Critical Speed Calculations

Resonant bending vibration may develop with thin screws rotating at high speed. Assuming a sufficiently rigid assembly, the resonant frequency can be estimated with the aid of the following method.

Worm gear screw jacks with multi-start screws are also available for applications with high lifting speeds. These versions run at a considerably lower screw speed and better efficiency for the same lifting speed. They are generally not self-locking.

$$n_{zul} = n_{krit} \cdot 0,8$$

- $n_{zul}$  Maximum permissible screw revolution speed [RPM]
- $n_{krit}$  Theoretical critical screw revolution speed [RPM]
- 0,8 Safety factor  $C_k$

## Case 1

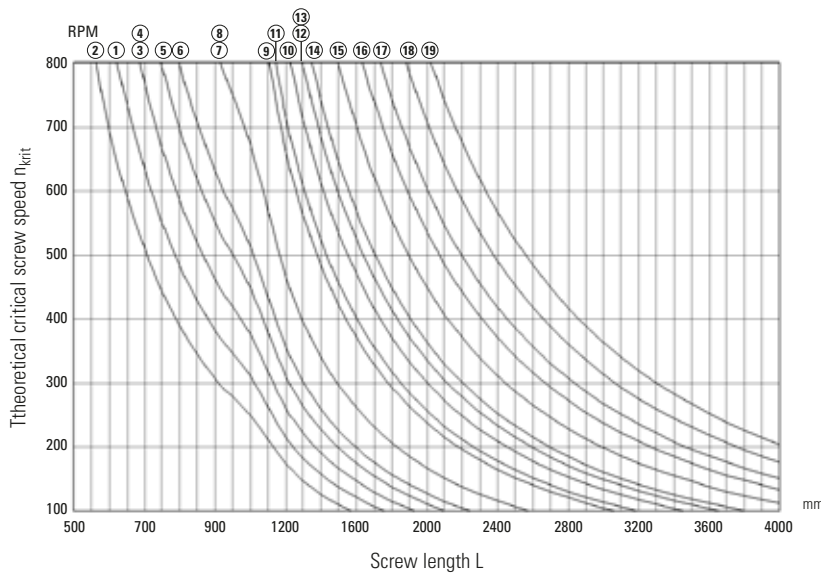

*no bearing*

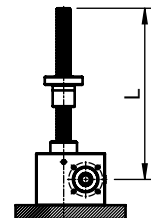

*fixed*

- |                    |                    |                    |                     |
|--------------------|--------------------|--------------------|---------------------|
| ① Multi0 – KGS1205 | ⑥ Multi2 – KGS2005 | ⑪ Multi4 – KGS4010 | ⑮ Jumbo3 – Tr80x10  |
| ② Tr14x4           | ⑦ Multi3 – KGS2505 | ⑫ Multi5 – Tr55x9  | ⑯ KGS8010           |
| ③ Multi1 – KGS1605 | ⑧ Tr30x6           | ⑬ KGS5010          | ⑰ Jumbo4 – Tr100x10 |
| ④ Tr18x4           | ⑨ Multi4 – Tr40x7  | ⑭ Jumbo1 – Tr60x9  | ⑱ Jumbo5 – Tr120x14 |
| ⑤ Multi2 – Tr20x4  | ⑩ KGS4005          | ⑰ Jumbo2 – Tr70x10 |                     |

# Critical Speed Calculations

## Case 3

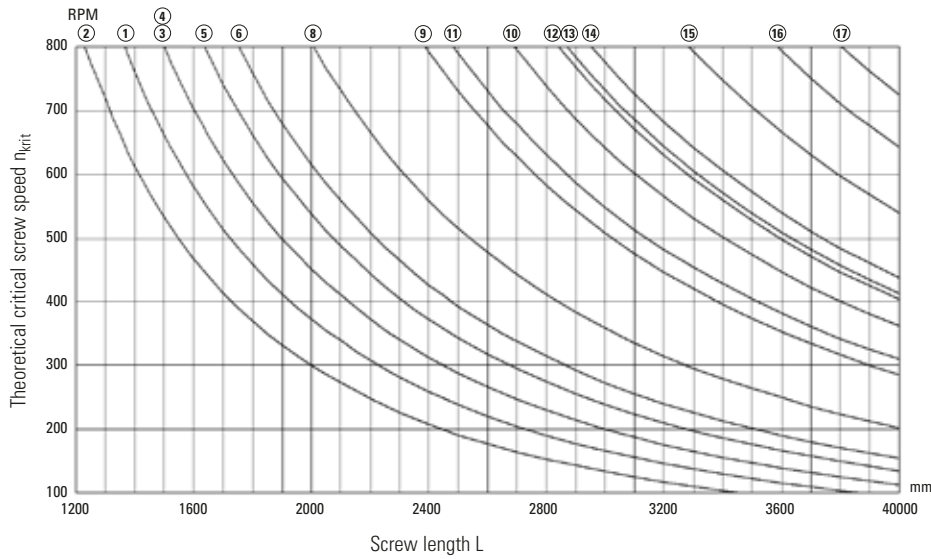

*Loose bearing*

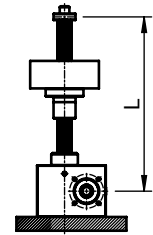

*fixed*

## Case 4

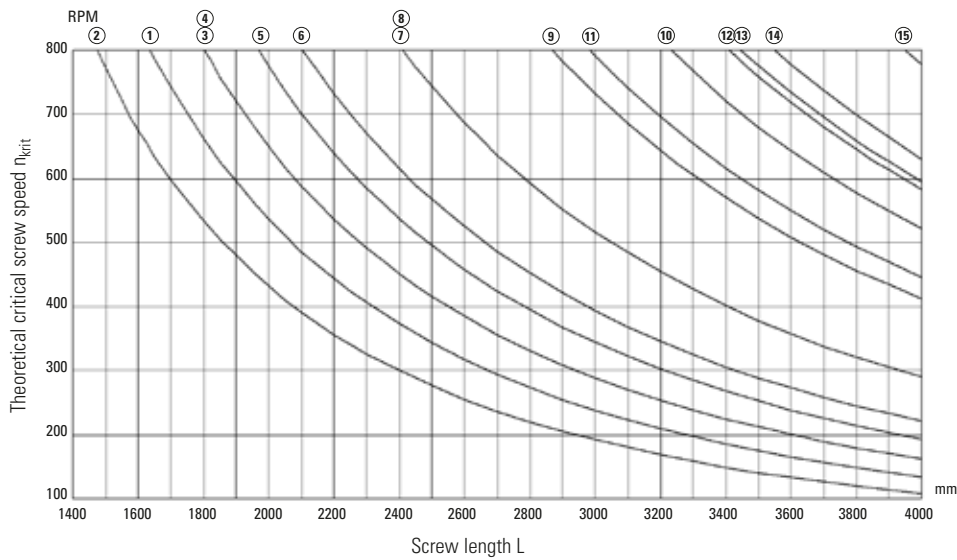

*Fixed bearing*

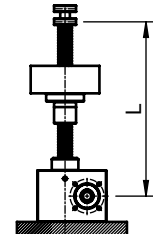

*fixed*

# Drive Torque and Holding Moment Calculations

## Required drive torque of a worm gear screw jack

The required drive torque of a worm gear screw jack is the result of the axial load acting on the jack screw, the transmission ratio and the efficiency. It should be noted that the breakaway torque may be considerably higher than the torque required for continuous running. This applies in particular to worm gear screw jacks with low efficiency after a long standstill period. The acceleration torque should be checked if necessary in cases with large screw pitches and very short run-up times.

$$M_T = \frac{F_{\text{eff}}}{2 \cdot \pi \cdot \eta} \cdot \frac{p}{i} + M_o$$

$M_T$	required drive torque of the worm gear screw drive at the worm shaft [Nm]. It should be noted that the start-up torque (breakaway torque and possibly acceleration torque) may be considerably higher than the torque required for continuous operation.
$F_{\text{eff}}$	actual force acting on the jack screw [kN].
$\eta$	is the efficiency of the worm gear screw jack in decimal notation, e. g. 0.32 instead of 32 % (for values, see table on page 14).
$p$	Pitch of the screw
$i$	Ratio of the worm gear screw jack
$M_o$	Idling torque is determined by measurements undertaken after a brief running-in period with liquid grease lubrication at room temperature. It represents an average value which may vary to a greater or lesser extent, depending on the running-in state, lubricant and temperature (for values, see table on page 14)
$\eta_k$	Efficiency of the bevel gear box $\eta_k = 0,85$ to $0,96$ depending on size of the bevel gears KRG (for values, see page 78)

## Required drive torque for a worm gear screw jack system

The required drive torque for a worm gear screw jack system (page 33) is relating on the drive torque values for the individual jacks with allowance for the static and dynamic frictional losses in transmission components. It is useful to draw a diagram illustrating the flow of forces.

A	$M = 2 \cdot M_T$
B	$M = 3 \cdot M_T$
C, G	$M = 4 \cdot M_T \cdot 1/\eta_k$
D	$M = 2 \cdot M_T \cdot 1/\eta_k$
E, F	$M = 2 \cdot M_T \cdot (1/\eta_k^2 + 1)$
H	$M = 4 \cdot M_T \cdot (1/\eta_k^2 + 1)$

## Required holding moment

$$M_d = \frac{F_{\text{eff}} \cdot p \cdot n \cdot 0,7}{2 \cdot \pi \cdot i} - M_o$$

$M_d$  is the required holding torque [Nm] of the Screw jack

## Lifetime, Force and Torque Considerations

### Lifetime calculations of a ball screw

The (nominal) lifetime of a ball screw drive can be calculated analogue to that of a ball bearing. Please note that vibrations and shocks reduce the lifetime of the ball screw drive. Dirt or lack of lubricant may significantly reduce the lifetime. Reduced life must also be expected in the case of very short strokes – please contact us in these cases.

$$L_{10} = \left( \frac{C}{F_{\text{eff}}} \right)^3 \cdot 10^6$$

$$L_h = \frac{L_{10}}{n \cdot 60}$$

C	Axial, dynamic load rating [N]. Centrally applied load [N] of constant force direction at which an appropriately large number of identical ball screw drives achieve a nominal lifetime of $10^6$ revolutions. Technical data for KGF/KGM, see page 45-46.
$L_{10}$	Lifetime of the ball screw drive. Expressed as the number of revolutions achieved or exceeded by 90 % ( $L_{10}$ ) of a sufficiently large sample of obviously identical ball screw drives before the first signs of material fatigue occur.
$L_h$	Lifetime in hours
n	Screw speed [RPM]

### Maximum drive torque $M_T$

$M_T$  is the maximum drive torque that can be applied to the worm shaft until the toothing is damaged or until the shaft breaks due to torsion. Please consider this in case of high static loads and when screw jacks are connected in series. Please feel free to ask our specialists.

### Acceleration values

3-phase asynchronous motor, 4-pole:

- Approx.  $0.5 \text{ m/s}^2$  (when switched on directly).

Servo motor:

- Max.  $5 \text{ m/s}^2$  (limited by max. drive torque).

When using gear jacks in combination with servo motors, note that:

- Greater masses are moved, compared with linear axes.
- Predominantly, constant speeds with different revolutions are used.
- Use is often in the area of the adjustment/positioning of equipment.
- Positions with comparatively short power-on times are travelled to, and high acceleration values are therefore less frequently required.
- High acceleration values have only a negligible effect on the overall stroke time, because of the low stroke speeds.

### Selection of drive motor

A suitable drive motor can be selected when the required drive torque and drive speed are known. After selecting a drive motor, check that it will not overload any of the worm gear screw jacks or transmission components. This risk may occur, in particular, in installations with several screw jacks if they are loaded unevenly. It will generally be necessary to install limit switches or torque-limiting couplings to protect the installation against impacting against end positions and obstacles.

### Forces and torque values on the motor shaft

Toothed-belt or chain drives may exert considerable radial forces on the motor shaft if a very small sprocket is used.

Please consult the motor manufacturer in cases of doubt.

### Selection of a bevel gear box

Selection of a bevel gearbox is the result of the following factors:

- Drive torque
- Drive speed (see dimensional tables)
- Duty cycle and drive power
- Forces and torque values acting on the ends of the shafts (please contact us in cases of doubt)

# Lifetime, Force and Torque Considerations

## Required drive speed

The required drive speed is the result of the desired lifting speed, the transmission ratio of the jack and the transmission ratio of the other transmission components. A particular lifting speed can normally be achieved in several ways. Correct selection depends on the following criteria:

- favourable efficiency
- minimum load on transmission components in order to achieve compact, low-cost design
- avoiding critical speeds for lead screws and connecting shafts.

Note: Forces and torque values can only be estimated by making simplified assumptions. The coefficients of friction of sliding pairs, and thus the heat which these generate, and the resultant service lifetime depend on load, speed, temperature and lubrication conditions. Critical speeds and buckling lengths depend on the rigidity and mass of the clamping systems and machine frames, etc.

$F_{eff}$  = Axial force acting on the jack screw

$F_S$  = Result of all lateral forces acting on the jack screw

$M$  = Torque of the lead screw or nut (not applicable for version V)

$V_H$  = Lifting speed

$F_{ax}$  = Axial force acting on drive shaft

$F_r$  = Radial force acting on drive shaft

$M_T$  = Drive torque

$n_T$  = Drive speed

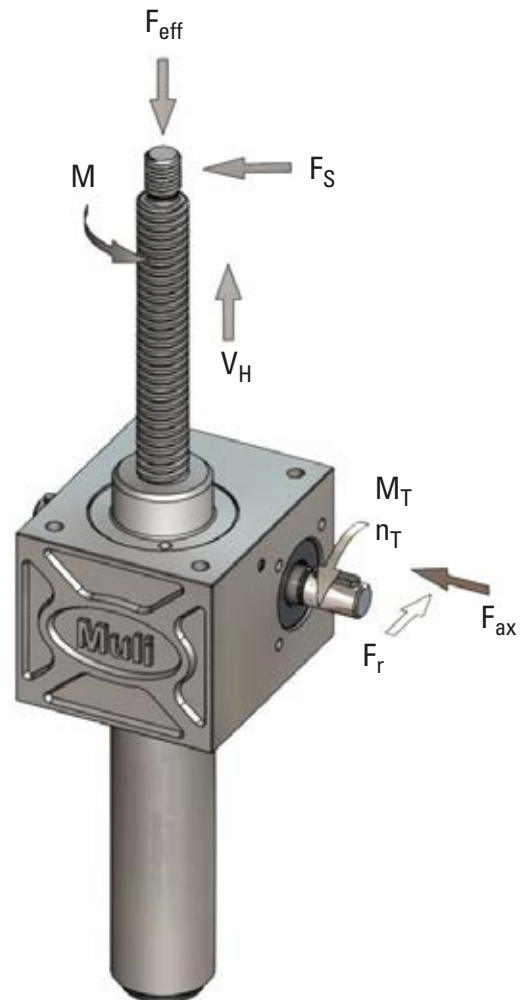

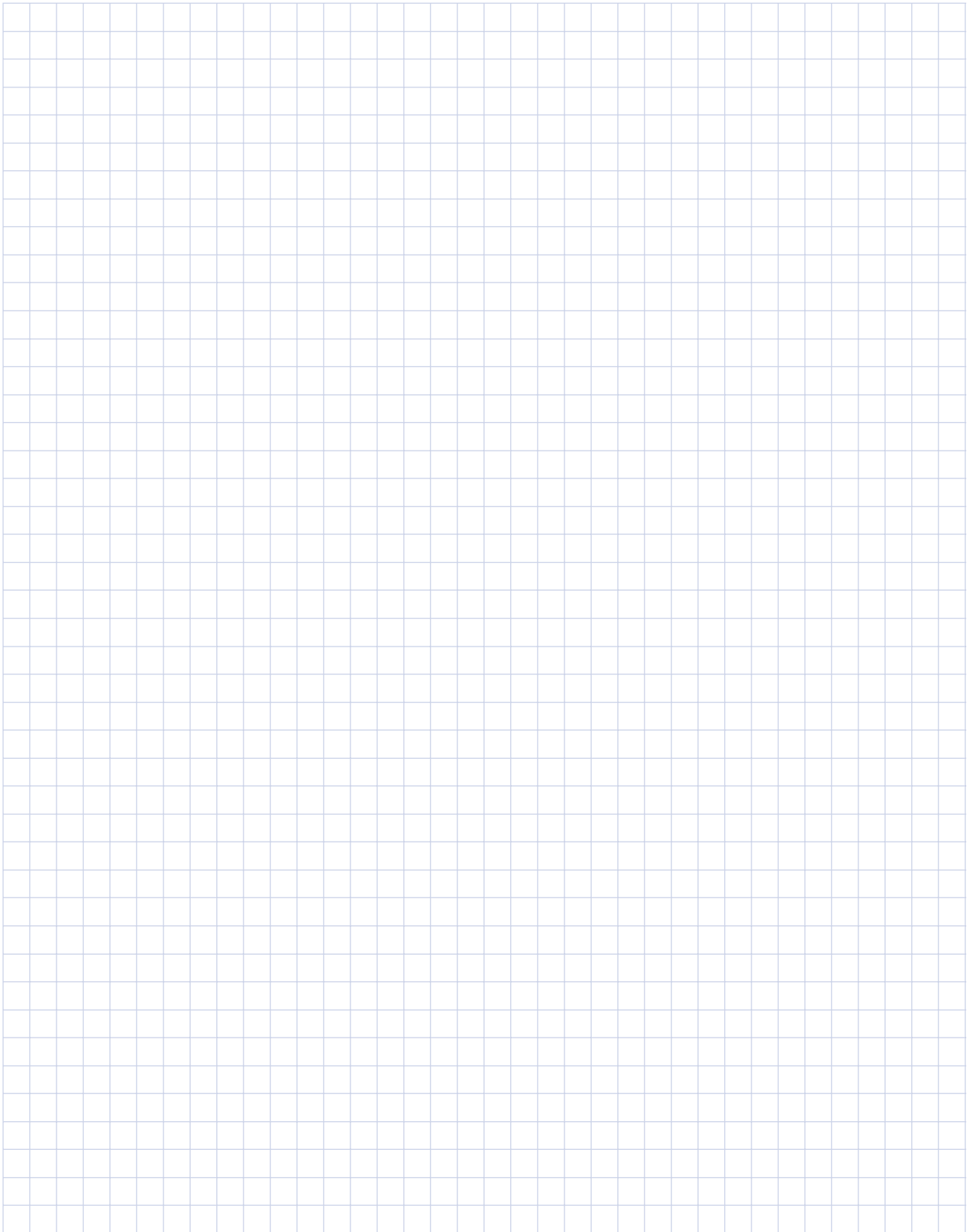

## Performance Tables

Data for MULI<sup>®</sup> 0 – JUMBO<sup>®</sup> 5 with gear ratio H and L with single-start trapezoidal screw and 20 % duty cycle per hour at a normal temperature of 20 °C. Additional performance data upon request.

MULI 0 – Screw Tr 14 x 4																																									
Speed [RPM]	Lifting speed [m/min]		Lifting force [kN]																																						
			2,5		2		1,5		0,75		0,5		0,25																												
			H	L	H	L	H	L	H	L	H	L	H	L																											
H	L	[Nm]	[kW]	[Nm]	[kW]	[Nm]	[kW]	[Nm]	[kW]	[Nm]	[kW]	[Nm]	[kW]	[Nm]	[kW]	[Nm]	[kW]	[Nm]	[kW]	[Nm]	[kW]																				
1500	1,50	0,375	1,20	0,18	0,40	0,10	0,90	0,15	0,30	0,10	0,70	0,20	0,20	0,10	0,40	0,10	0,10	0,20	0,10	0,10	0,10	0,10																			
1000	1,00	0,250		0,12																			0,10	0,10	0,10	0,10	0,10	0,10	0,10	0,10	0,10	0,10	0,10	0,10	0,10	0,10	0,10	0,10	0,10	0,10	
750	0,75	0,187		0,10																			0,10	0,10	0,10	0,10	0,10	0,10	0,10	0,10	0,10	0,10	0,10	0,10	0,10	0,10	0,10	0,10	0,10	0,10	0,10
500	0,50	0,125		0,10																			0,10	0,10	0,10	0,10	0,10	0,10	0,10	0,10	0,10	0,10	0,10	0,10	0,10	0,10	0,10	0,10	0,10	0,10	0,10

MULI 1 – Screw Tr 18 x 4																																						
Speed [RPM]	Lifting speed [m/min]		Lifting force [kN]																																			
			5		4		3		2		1,5		1																									
			H	L	H	L	H	L	H	L	H	L	H	L																								
H	L	[Nm]	[kW]	[Nm]	[kW]	[Nm]	[kW]	[Nm]	[kW]	[Nm]	[kW]	[Nm]	[kW]	[Nm]	[kW]	[Nm]	[kW]	[Nm]	[kW]	[Nm]	[kW]																	
1500	1,50	0,375	2,61	0,41	0,83	0,13	2,09	0,33	0,10	1,58	0,25	0,08	0,17	0,05	0,13	0,04	0,09	0,09	0,03	0,06	0,03	0,03																
1000	1,00	0,250		0,27	0,09	0,22		0,07															0,17	0,05	0,11	0,04	0,08	0,03	0,06	0,03	0,06	0,03	0,06	0,03	0,06	0,03	0,03	
750	0,75	0,187		0,20	0,83	0,06		2,09															0,16	0,67	1,58	0,12	0,51	0,04	1,07	0,35	0,03	0,81	0,06	0,27	0,02	0,55	0,04	0,19
500	0,50	0,125		0,14	0,04	0,04		2,09															0,11	0,03	0,08	0,08	0,03	0,06	0,06	0,02	0,04	0,01	0,03	0,03	0,03	0,03	0,03	0,01

MULI 2 – Screw Tr 20 x 4																														
Speed [RPM]	Lifting speed [m/min]		Lifting force [kN]																											
			10		7,5		5		4		3		2																	
			H	L	H	L	H	L	H	L	H	L	H	L																
H	L	[Nm]	[kW]	[Nm]	[kW]	[Nm]	[kW]	[Nm]	[kW]	[Nm]	[kW]	[Nm]	[kW]	[Nm]	[kW]	[Nm]	[kW]	[Nm]	[kW]	[Nm]	[kW]									
1500	1,50	0,375	5,60	0,88	1,83	0,29	4,23	0,66	1,40	0,22	2,86	0,45	0,97	0,15	2,31	0,36	0,79	0,12	1,76	0,28	0,62	0,10	1,21	0,19						
1000	1,00	0,250		0,59	0,19	0,44		0,15	0,30	0,10	0,24	0,08	0,18	0,06	0,14	0,06		0,14		0,06		0,14		0,06	0,14	0,06	0,14	0,06	0,05	
750	0,75	0,187		0,44	1,83	0,14		4,23	0,33	1,40	0,11	2,86	0,22	0,97	0,08	2,31		0,18		0,79		0,06		1,76	0,14	0,62	0,05	1,21	0,09	0,45
500	0,50	0,125		0,29	0,10	0,10		4,23	0,22	0,07	0,15	0,05	0,15	0,05	0,12	0,04		0,12		0,04		0,09		1,76	0,09	0,03	0,06	0,06	0,06	0,02

**!** The screw jacks can overheat or an excessive area pressure develop in the screw thread at the speeds stated in the grey fields with white text. For this range no liability can be requested.



# Performance Tables

MULI 3 – Screw Tr 30 x 6																												
Speed [RPM]	Lifting speed [m/min]		Lifting force [kN]																									
			25				20				15				10				5				2,5					
			H		L		H		L		H		L		H		L		H		L		H		L			
			[Nm]	[kW]	[Nm]	[kW]	[Nm]	[kW]	[Nm]	[kW]	[Nm]	[kW]	[Nm]	[kW]	[Nm]	[kW]	[Nm]	[kW]	[Nm]	[kW]	[Nm]	[kW]	[Nm]	[kW]	[Nm]	[kW]		
1500	1,50	0,375	13,88	2,81	4,45	0,70	11,13	1,75	3,58	0,56	8,39	1,32	2,72	0,43	5,64	0,89	1,85	0,29	2,90	0,45	0,99	0,15	1,52	0,24	0,55	0,09		
1000	1,00	0,250		1,45	4,45	0,47		1,17	3,58	0,38		8,39	0,88	0,28		0,59		1,85		0,19		0,30		0,10		0,16	0,06	
750	0,75	0,187		1,09	4,45	0,35		0,87	3,58	0,28		8,39	0,66	2,72		0,21		0,44		1,85		0,15		0,23		0,08	0,12	0,04
500	0,50	0,125		0,73	4,45	0,23		11,13	0,58	0,19		8,39	0,44	0,14		0,30		1,85		0,10		0,15		0,05		0,08	0,03	

MULI 4 – Screw Tr 40 x 7																																	
Speed [RPM]	Lifting speed [m/min]		Lifting force [kN]																														
			50				40				30				20				10				5										
			H		L		H		L		H		L		H		L		H		L		H		L								
			[Nm]	[kW]	[Nm]	[kW]	[Nm]	[kW]	[Nm]	[kW]	[Nm]	[kW]	[Nm]	[kW]	[Nm]	[kW]	[Nm]	[kW]	[Nm]	[kW]	[Nm]	[kW]	[Nm]	[kW]	[Nm]	[kW]							
1500	1,50	0,375	30,97	4,86	1,53	24,85	3,90	7,83	1,23	18,72	2,94	5,94	0,93	12,60	1,98	4,04	0,63	6,47	1,02	2,15	0,34	3,41	0,54	1,20	0,19								
1000	1,00	0,250		3,24	9,73		1,02	2,60	7,83		0,82	18,72	1,96		0,62		0,62		12,60		1,32		4,04		0,42	6,47	0,68	2,15	0,22	3,41	0,36	1,20	0,13
750	0,75	0,187		2,43	9,73		0,76	1,95	7,83		0,62	18,72	1,47		0,47		0,47		12,60		0,99		4,04		0,32	6,47	0,51	2,15	0,17	3,41	0,27	1,20	0,09
500	0,50	0,125		1,62	9,73		0,51	1,30	7,83		0,41	18,72	0,98		0,31		0,31		12,60		0,66		4,04		0,21	6,47	0,34	2,15	0,11	3,41	0,18	1,20	0,06

MULI 5 – Screw Tr 55 x 9																																
Speed [RPM]	Lifting speed [m/min]		Lifting force [kN]																													
			100				80				60				40				20				10									
			H		L		H		L		H		L		H		L		H		L		H		L							
			[Nm]	[kW]	[Nm]	[kW]	[Nm]	[kW]	[Nm]	[kW]	[Nm]	[kW]	[Nm]	[kW]	[Nm]	[kW]	[Nm]	[kW]	[Nm]	[kW]	[Nm]	[kW]	[Nm]	[kW]	[Nm]	[kW]						
1500	1,50	0,375	67,19	10,55	3,37	53,92	8,47	17,27	2,71	13,08	6,38	13,08	2,05	27,38	4,30	8,89	1,40	14,11	2,22	4,70	0,74	7,47	1,17	2,61	0,41							
1000	1,00	0,250		7,04	21,46		2,25	5,65	17,27		1,81	40,65	4,26		1,37		27,38		2,87		8,89		0,93		14,11	1,48	4,70	0,49	7,47	0,78	2,61	0,27
750	0,75	0,187		5,28	21,46		1,69	4,23	17,27		1,36	40,65	3,19		1,03		13,08		1,03		8,89		0,70		14,11	1,11	4,70	0,37	7,47	0,59	2,61	0,20
500	0,50	0,125		3,52	21,46		1,12	2,82	17,27		0,90	40,65	2,13		0,68		13,08		0,68		8,89		0,47		14,11	0,74	4,70	0,25	7,47	0,39	2,61	0,14

**!** The screw jacks can overheat or an excessive area pressure develop in the screw thread at the speeds stated in the grey fields. For this range no liability can be requested.

## Performance Tables

Jumbo 1 – Screw Tr 60 x 9																									
Speed [RPM]	Lifting speed [m/min]		Lifting force [kN]																						
			150				120				100				70				50						
			H		L		H		L		H		L		H		L		H		L				
			[Nm]	[kW]	[Nm]	[kW]	[Nm]	[kW]	[Nm]	[kW]	[Nm]	[kW]	[Nm]	[kW]	[Nm]	[kW]	[Nm]	[kW]	[Nm]	[kW]	[Nm]	[kW]			
1500	1,50	0,375	104,73	16,44	5,30	33,74	13,18	4,26	83,96	8,79	2,84	27,11	7,34	22,69	2,37	70,11	5,50	1,78	49,34	3,87	16,05	1,26	11,63	5,57	1,83
1000	1,00	0,250		10,96	3,53		6,59	2,13		5,50	22,69		2,37	3,87	16,05		1,26	35,50		3,72	1,22				
750	0,75	0,187		8,22	2,65		4,39	1,42		3,67	22,69		1,19	2,58	16,05		0,84	35,50		2,79	0,91				
500	0,50	0,125		5,48	1,77		4,39	1,42		3,67	22,69		1,19	2,58	16,05		0,84	35,50		1,86	0,61				

Jumbo 2 – Screw Tr 70 x 10																									
Speed [RPM]	Lifting speed [m/min]		Lifting force [kN]																						
			200				150				100				75				50						
			H		L		H		L		H		L		H		L		H		L				
			[Nm]	[kW]	[Nm]	[kW]	[Nm]	[kW]	[Nm]	[kW]	[Nm]	[kW]	[Nm]	[kW]	[Nm]	[kW]	[Nm]	[kW]	[Nm]	[kW]	[Nm]	[kW]			
1500	1,50	0,375	146,04	22,94	7,50	47,75	17,25	5,66	109,85	11,50	3,77	36,05	7,71	24,34	2,55	73,66	5,78	1,91	55,56	4,36	18,48	1,45	37,47	5,88	1,98
1000	1,00	0,250		15,29	5,00		8,62	2,83		7,71	24,34		2,55	5,82	18,48		1,93	37,47		3,92	1,32				
750	0,75	0,187		11,47	3,75		5,75	1,89		5,78	24,34		1,91	4,36	18,48		1,45	37,47		2,94	0,99				
500	0,50	0,125		7,65	2,50		5,75	1,89		3,85	24,34		1,27	2,91	18,48		0,97	37,47		1,96	0,66				

Jumbo 3 – Screw Tr 80 x 10																									
Speed [RPM]	Lifting speed [m/min]		Lifting force [kN]																						
			250				200				150				100				50						
			H		L		H		L		H		L		H		L		H		L				
			[Nm]	[kW]	[Nm]	[kW]	[Nm]	[kW]	[Nm]	[kW]	[Nm]	[kW]	[Nm]	[kW]	[Nm]	[kW]	[Nm]	[kW]	[Nm]	[kW]	[Nm]	[kW]			
1500	1,50	0,375	200,36	31,46	10,57	67,32	25,21	8,49	160,56	16,80	5,66	54,05	12,64	40,78	4,27	120,75	9,48	3,20	80,94	6,35	27,51	2,16	14,24	6,46	2,24
1000	1,00	0,250		20,97	7,05		16,80	5,66		12,64	40,78		4,27	8,47	27,51		2,88	41,13		4,30	1,49				
750	0,75	0,187		15,73	5,28		12,60	4,24		9,48	40,78		3,20	6,35	27,51		2,16	41,13		3,23	1,12				
500	0,50	0,125		10,49	3,52		8,40	2,83		6,32	40,78		2,13	4,24	27,51		1,44	41,13		2,15	0,75				

! The screw jacks can overheat or an excessive area pressure develop in the screw thread at the speeds stated in the grey fields with white text. For this range no liability can be requested.

## Performance Tables

Jumbo 4 – Screw Tr 100 x 10																						
Speed [RPM]	Lifting speed [m/min]		Lifting force [kN]																			
			350				300				150				100				50			
			H		L		H		L		H		L		H		L		H		L	
			[Nm]	[kW]	[Nm]	[kW]	[Nm]	[kW]	[Nm]	[kW]	[Nm]	[kW]	[Nm]	[kW]	[Nm]	[kW]	[Nm]	[kW]	[Nm]	[kW]	[Nm]	[kW]
1500	1,50	0,375	325,51	51,47	107,46	16,83	279,25	44,12	92,27	14,49	140,45	22,06	46,71	7,34	94,18	14,79	4,95	31,52	7,53	47,92	2,57	
1000	1,00	0,250		34,31	11,25	29,41		9,66		14,71	4,89	9,86		3,30		5,02	1,71					
750	0,75	0,187		25,74	107,46	8,44		22,06		7,25	140,45	11,03		3,67		7,40	2,48		3,76		16,34	1,28
500	0,50	0,125		17,16	5,63	279,25		14,62		4,83	7,35	2,45		4,93		1,65	2,51		0,86			

Jumbo 5 – Screw Tr 120 x 14																						
Speed [RPM]	Lifting speed [m/min]		Lifting force [kN]																			
			500				400				300				200				100			
			H		L		H		L		H		L		H		L		H		L	
			[Nm]	[kW]	[Nm]	[kW]	[Nm]	[kW]	[Nm]	[kW]	[Nm]	[kW]	[Nm]	[kW]	[Nm]	[kW]	[Nm]	[kW]	[Nm]	[kW]	[Nm]	[kW]
1500	1,50	0,375	441,62	69,44	147,68	24,04	353,69	55,56	118,43	18,60	265,76	41,67	89,17	14,01	177,83	27,78	59,91	9,41	89,90	14,12	4,82	
1000	1,00	0,250		46,30	12,25	37,04		12,40		27,78	9,34	18,62		6,27	9,41	3,21						
750	0,75	0,187		34,72	147,68	9,17		27,78		9,30	20,87	7,00		177,83	13,97	4,71		7,06		30,66	2,41	
500	0,50	0,125		23,15	6,13	353,69		18,52		6,20	265,76	13,91		4,67	9,31	3,14		4,71		1,61		

! The screw jacks can overheat or an excessive area pressure develop in the screw thread at the speeds stated in the grey fields. For this range no liability can be requested.

# Order Code

## Order code structure

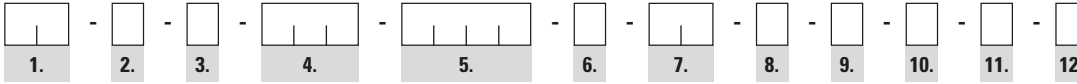

### 1. Size

M0 - M5 = Muli 0 to Muli 5  
J1 - J5 = Jumbo 1 to Jumbo 5

### 2. Type

N = axial translating screw  
R = rotating screw  
V = axial translating screw and anti-rotation

### 3. Gear ratio

H = high ratio  
L = low ratio

### 4. Screw type

TGS = trapezoidal screw  
KGS = ball screw

### 5. Stroke [mm]

• • • •

### 6. Screw end

G = standard screw end D<sub>3</sub> (only for type N and V)  
Z = cylindrical end (only for type R)  
0 = no end machining  
S = special to customer specification

### 7. End fitting (for version N, V with standard screw end G)

00 = no end fitting (standard for version R)  
BP = top plate  
GA = fork end  
GK = clevis end

### 8. Bellows

0 = without  
F = with 1 pc. bellow (for R-version please advise if you would need a 2nd bellow cover)

### 9. Nut (for version R; when using N, V version = 0) \*

0 = without nut (always for type N and V)  
1 = trapezoidal nut (for type R with screw type TGS)  
2 = flanged ball nut (for type R with screw type KGS)  
3 = cylindrical ball nut (for type R with screw type KGS)  
\* flange of nut shows towards screw end as standard

### 10. Stop collar

0 = without (always for type R)  
A = with (standard for type N and V with screw type KGS)

### 11. Special features

0 = without  
Z = standard accessories as per catalog \*  
S = custom design \*  
\* please describe in field 21 on page 30 what accessories or/and custom design changes you require

### 12. Screw dimension (only for MULI 4 KGS)

1 = KGS 4005 (possible for size M4 only)  
2 = KGS 4010 (possible for size M4 only)

## Order code example



# Checklist

Fill out the form to your best ability. Enclose any drawings, specifications, outlines and any other information you may have regarding the application. When done please e-mail or print it out and send in by fax. Do not hesitate to contact us if you have any questions.

Send fax to +49 (0) 7022-504-405 or email to [sales.germany@thomsonlinear.com](mailto:sales.germany@thomsonlinear.com).

\* = required information

Date \_\_\_\_\_

Company: \* \_\_\_\_\_

Your project code (if any): \_\_\_\_\_

Contact: \* \_\_\_\_\_

Department: \_\_\_\_\_

Street/ P.O. box address: \* \_\_\_\_\_

Phone: \* \_\_\_\_\_

ZIP, City: \* \_\_\_\_\_

Fax: \* \_\_\_\_\_

Country: \* \_\_\_\_\_

E-mail: \* \_\_\_\_\_

1. Application description: \_\_\_\_\_  
 \_\_\_\_\_  
 \_\_\_\_\_

2. Complete ordering code for desired scrow jack model:

	-		-		-		-		-		-		-		-		-		-		-	
1.		2.		3.		4.		5.		6.		7.		8.		9.		10.		11.		12.

3. Screw jack size \_\_\_\_\_

4. Screw jack type \_\_\_\_\_

5. Screw version Trapez. screw  Ball screw  \_\_\_\_\_

6. Axial static load [Nm] Push: \_\_\_\_\_ Pull: \_\_\_\_\_

7. Axial dynamic load [Nm] Push: \_\_\_\_\_ Pull: \_\_\_\_\_

8. Type of load Constant  Oscillating  Reversing  Shock  Vibrating  \_\_\_\_\_

9. Bearing case Case 1  Case 2  Case 3  Case 4  \_\_\_\_\_

10. Number of screw jacks that share the load 1  2  3  4  \_\_\_\_\_

11. Mounting position Vertical screw pointing up  Vertical screw pointing down  Horizontal  \_\_\_\_\_

12. Linear speed [mm/min] \_\_\_\_\_

13. Stroke length [mm] \_\_\_\_\_

14. Duty cycle [%/hour] \_\_\_\_\_

Continue on next page >>>

# Checklist

15. Cycle time [s]

---

16. Usage of external guide(s)      No       Yes       If yes, enter total friction factor for the guide(s)

---

17. Shift work      One shift per day       Two shifts per day       Three shifts day

---

18. Operation temperature (if under +10 °C or/and over +60 °C)

---

19. Operation relative humidity [%]

---

20. Operation conditions (select the appropriate)      Chips, dirt, dust       Hazardous materials       Outdoor operation       Personal transportation

---

21. Desired options or custom design request (see catalog for available options)

---

# Checklist

For N/V-versions

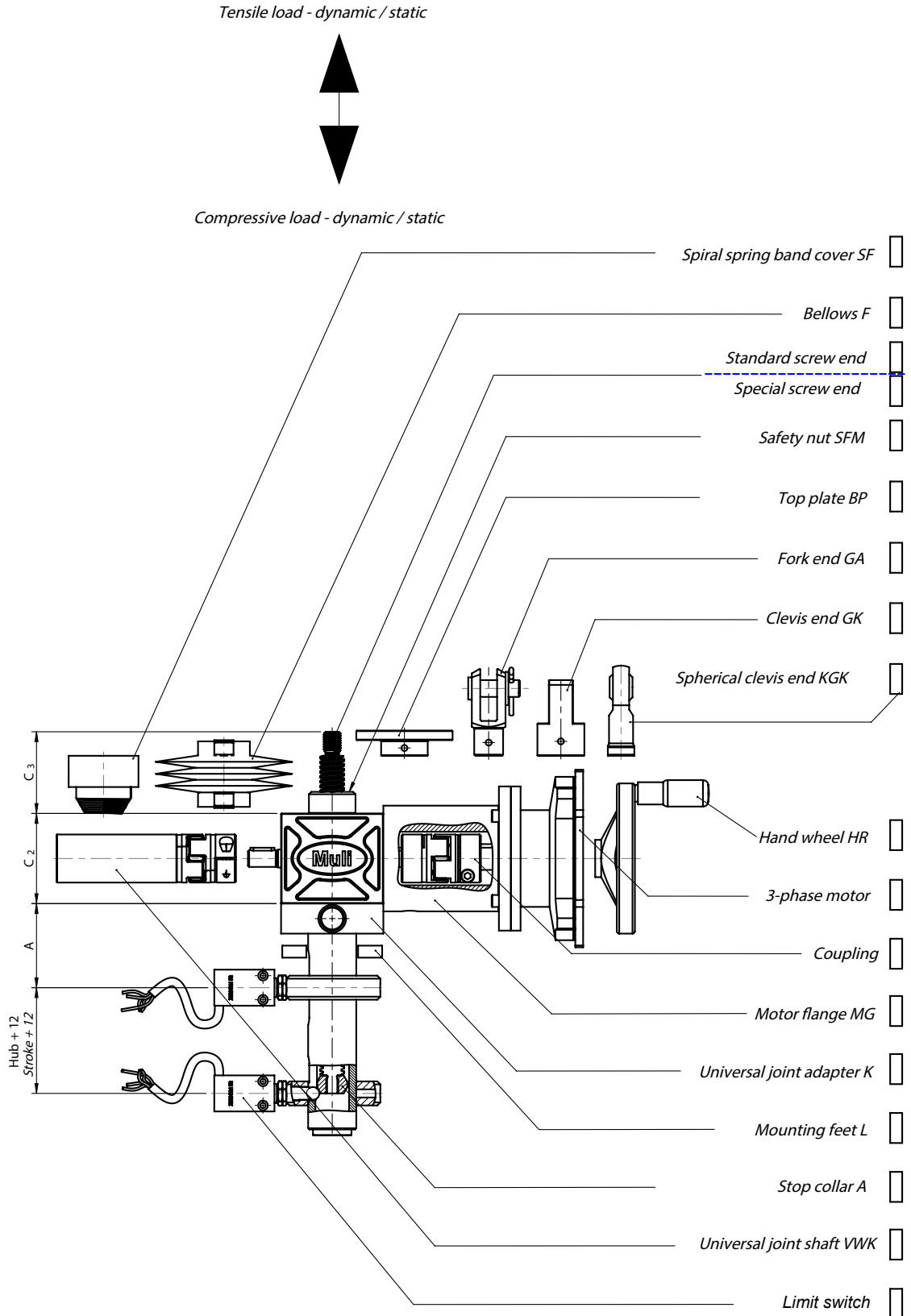

# Checklist

For N/V-versions

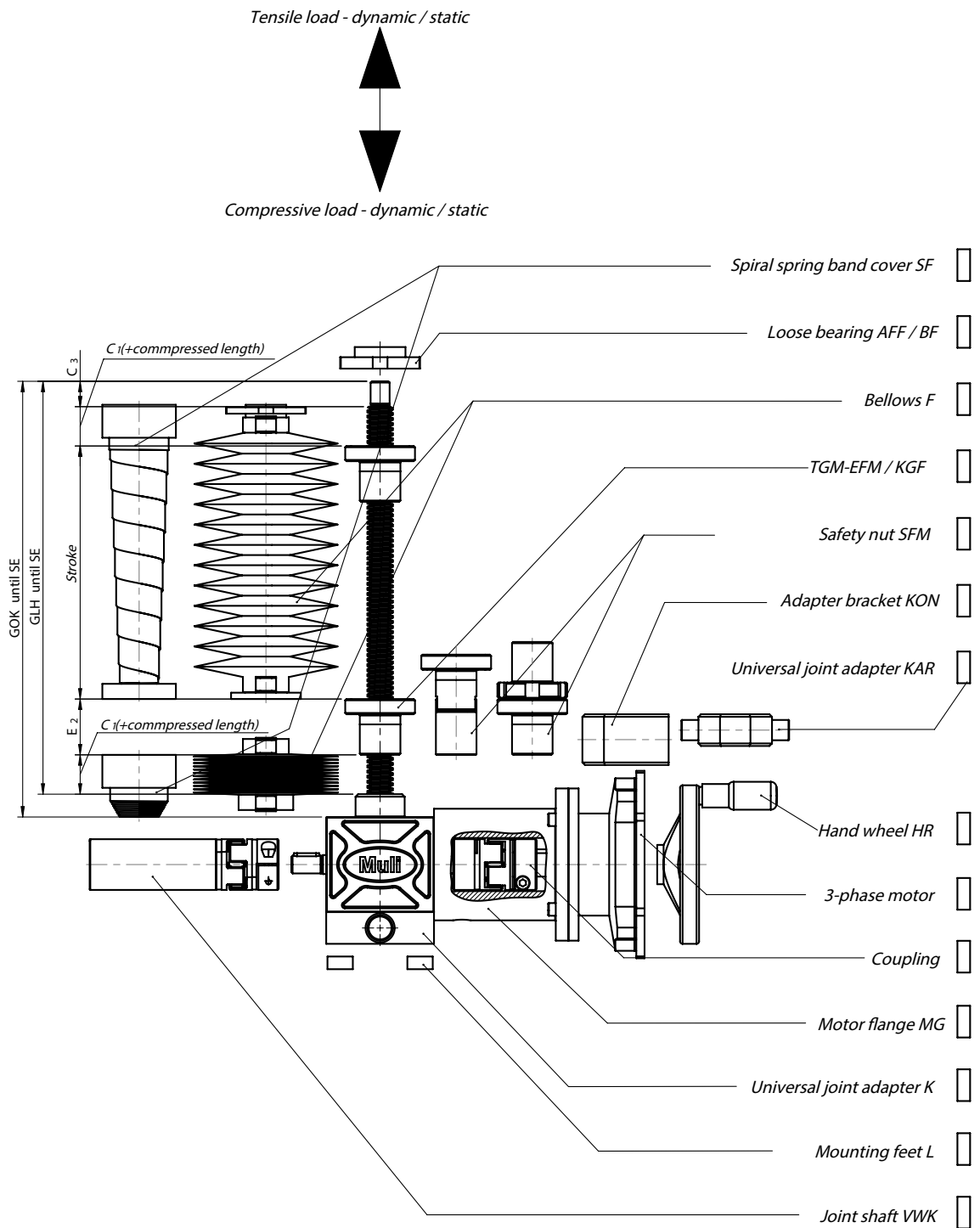



# Screw Jack System Configurations

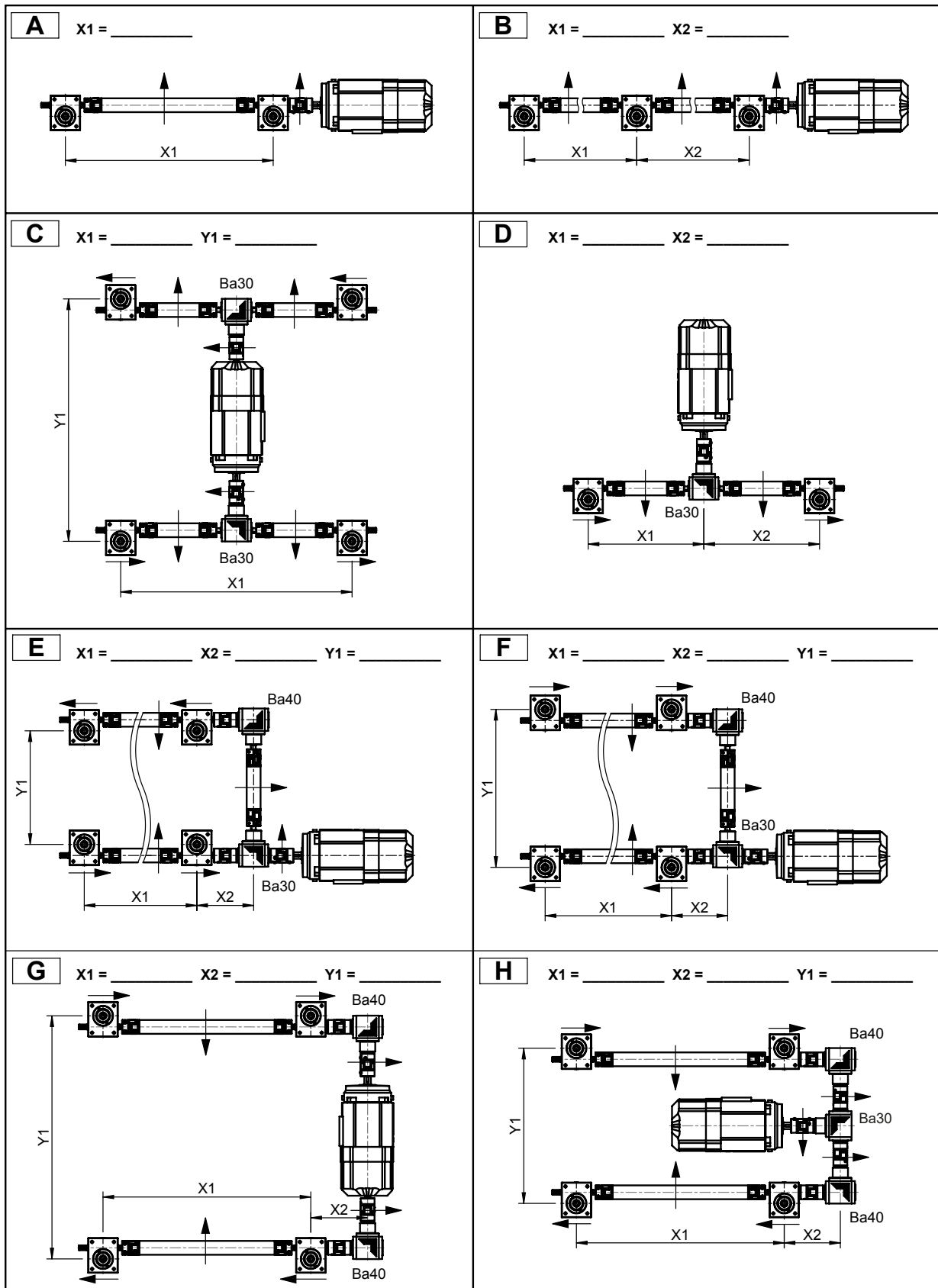

# Dimensions

## Version N and V

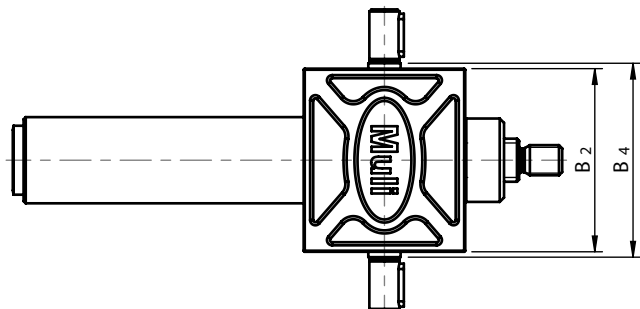
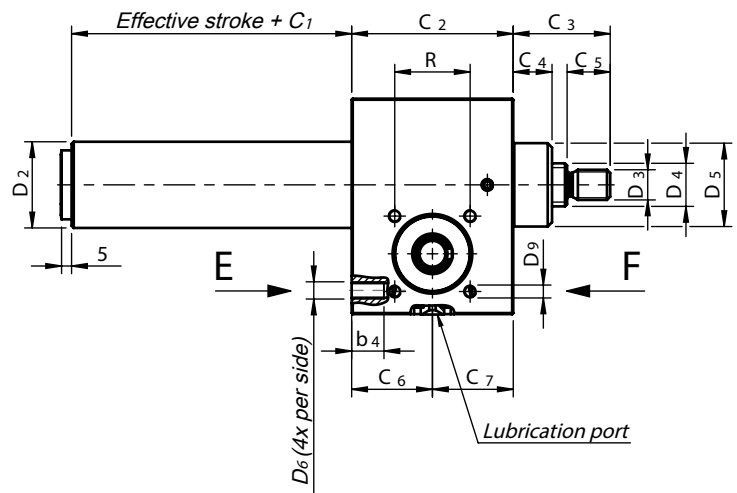
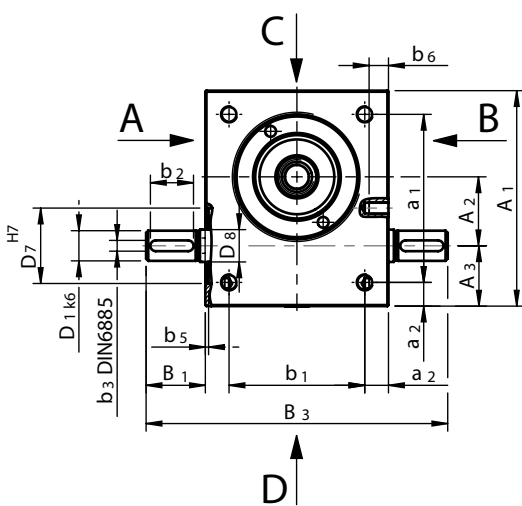

**Note!** If attachments are to be fitted, please specify on which side (A/B).

# Dimensions

## Version N and V

Dimensions [mm]																	
Size	A <sub>1</sub> <sup>1)</sup>	A <sub>2</sub>	A <sub>3</sub>	a <sub>1</sub>	a <sub>2</sub>	B <sub>1</sub>	B <sub>2</sub>	B <sub>3</sub>	B <sub>4</sub>	b <sub>1</sub>	b <sub>2</sub>	b <sub>3</sub>	b <sub>4</sub>	b <sub>5</sub>	C <sub>1</sub> <sup>8)</sup>	C <sub>2</sub>	C <sub>3</sub> <sup>2)3)</sup>
MULI 0	60	20	18	48	6	21	50	92	52	38	14	3	7	–	20(40)	50	27(33)
MULI 1	80	25	24	60	10	24	72	120	77	52	18	3	13	1.5	20(60)	62	35(46)
MULI 2	100	32	28	78	11	27.5	85	140	90	63	20	5	15	1.5	30(50)	75	45(48.5)
MULI 3	130	45	31	106	12	45	105	195	110	81	36	5	15	2	30(60)	82	50
MULI 4	180	63	39	150	15	47.5	145	240	150	115	36	6	16	2	45(70)	117	65
MULI 5	200	71	46	166	17	67.5	165	300	170	131	56	8	30	2.5	55(75)	160	95
JUMBO 1	210	71	49	170	20	65	195	325	200	155	56	8	40	8	55	175	95
JUMBO 2	240	80	60	190	25	67.5	220	355	225	170	56	8	45	8	60	165	110
JUMBO 3	240	80	60	190	25	67.5	220	355	225	170	56	8	45	8	60	165	110
JUMBO 4	290	100	65	230	30	65	250	380	254	190	56	10	54	8	65	220	140
JUMBO 5	360	135	75	290	35	100	300	500	305	230	90	14	80	8	90	266	200

Dimensions [mm]																	
Size	C <sub>4</sub> <sup>3)</sup>	C <sub>5</sub>	C <sub>6</sub>	C <sub>7</sub>	D <sub>1</sub> <sup>4)</sup>	D <sub>2</sub> <sup>5)</sup>	D <sub>3</sub> <sup>6)</sup>	D <sub>4</sub> TR	D <sub>4</sub> KGS	D <sub>5</sub> <sup>3)</sup>	D <sub>6</sub>	D <sub>7</sub>	D <sub>8</sub>	D <sub>9</sub> x b <sub>6</sub> <sup>7)</sup>	R(TK) <sup>3)7)</sup>	V-KGT <sup>5)</sup>	
MULI 0	12(19)	12	25	25	9 x 20	28	M8 x 1.25	14 x 4	1205	26(36)	M6	–	–	M5 x 3,5	24(34)	25 x 25	
MULI 1	12(23)	19	31	31	10 x 21.5	33	M12 x 1.75	18 x 4	1605	29.6(48)	M8	28	12	M5 x 8	32(45.25)	30 x 30	
MULI 2	18(21.5)	20	37.5	37.5	14 x 25	40	M14 x 2.0	20 x 4	2005	38.7(61)	M8	35	15	M6 x 9	35(49.5)	40 x 40	
MULI 3	23	22	41	41	16 x 42.5	50	M20 x 2.5	30 x 6	2505	46	M10	35	17	M8 x 10	44(62.2)	50 x 50	
MULI 4	32	29	58.5	58.5	20 x 45	60	M30 x 3.5	40 x 7	4005/4010	60	M12	52	25	M10 x 14	55(77.8)	60 x 60	
MULI 5	40	48	80	80	25 x 65	82	M36 x 4	55 x 9	5010	85	M20	52	28	M12 x 16	60(84.85)	80 x 80	
JUMBO 1	40	48	87.5	87.5	25 x 62.5	90	M48 x 2	60 x 9	–	90	M24	52	28	M12 x 16	60(84.85)	–	
JUMBO 2	40	58	82.5	82.5	30 x 65	115	M56 x 2	70 x 10	–	105	M30	58	32	M12 x 18	(80)	–	
JUMBO 3	40	58	82.5	82.5	30 x 65	115	M64 x 3	80 x 10	8010	120	M30	58	32	M12 x 18	(80)	120 x 120	
JUMBO 4	50	78	106	114	35 x 62.5	150	M72 x 3	100 x 10	–	145	M36	85	40	–	–	–	
JUMBO 5	60	118	133	133	48 x 97.5	180	M100 x 3	120 x 14	–	170	M42	90	50	–	–	–	

Note: Subject to change without prior notice.

<sup>1)</sup> Dimension A1 for Muli 0–2 to DIN 1688-T1/GTA 16, from MULI3 to DIN 1685 GTB 18

<sup>2)</sup> This dimension refers to the closed height and represents a minimum. It must be increased if bellows are used (see page 40-41).

<sup>3)</sup> The values in brackets refer to version with ball screw

<sup>4)</sup> Diameter and length to shoulder.

<sup>5)</sup> Square protection pipe for Muli0-V-TGS/KGS and for ball screw as anti-rotation device (see V-KGT).

<sup>6)</sup> In accordance to DIN 13 screw thread: MULI. In accordance to DIN 13 fine pitch thread: JUMBO.

<sup>7)</sup> JUMBO 2 & 3 only 3 holes. JUMBO 4 & 5 without holes.

<sup>8)</sup> The value in brackets refer to if square protective tube is used.

# Dimensions

## Version R

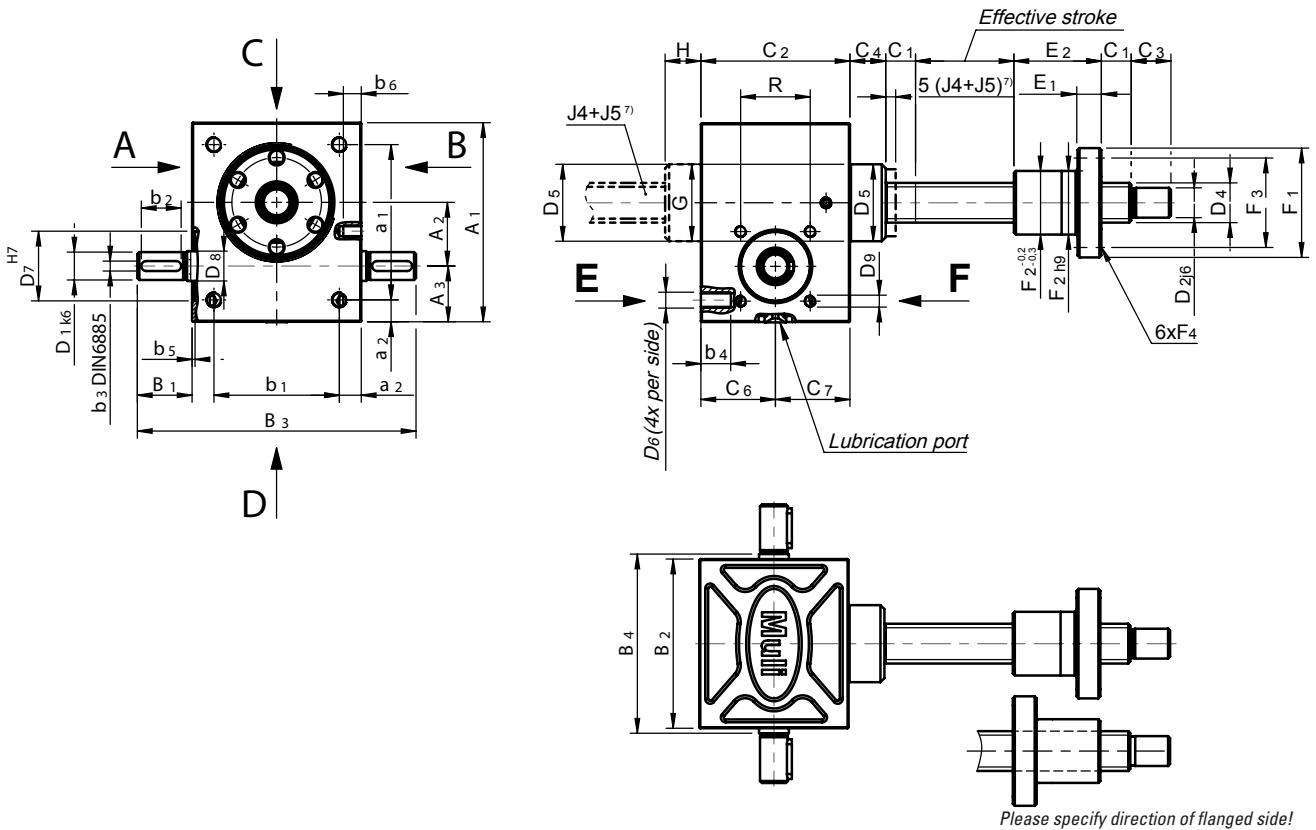

**Note!** If attachments are to be fitted, please specify on which side (A/B).

# Dimensions

## Version R

Dimensions [mm]																				
Size	A <sub>1</sub> <sup>1)</sup>	A <sub>2</sub>	A <sub>3</sub>	a <sub>1</sub>	a <sub>2</sub>	B <sub>1</sub>	B <sub>2</sub>	B <sub>3</sub>	B <sub>4</sub>	b <sub>1</sub>	b <sub>2</sub>	b <sub>3</sub>	b <sub>4</sub>	b <sub>5</sub>	C <sub>1</sub>	C <sub>2</sub>	C <sub>3</sub>	C <sub>4</sub>	C <sub>6</sub>	C <sub>7</sub>
MULI 0	60	20	18	48	6	21	50	92	52	38	14	3	12	—	10	50	12	12	25	25
MULI 1	80	25	24	60	10	24	72	120	77	52	18	3	13	1.5	12	62	15	12	31	31
MULI 2	100	32	28	78	11	27.5	85	140	90	63	20	5	15	1.5	15	75	20	18	37.5	37.5
MULI 3	130	45	31	106	12	45	105	195	110	81	36	5	15	2	20	82	25	23	41	41
MULI 4	180	63	39	150	15	47.5	145	240	150	115	36	6	16	2	25	117	30	32	58.5	58.5
MULI 5	200	71	46	166	17	67.5	165	300	170	131	56	8	30	2.5	25	160	45	40	80	80
JUMBO 1	210	71	49	170	20	65	195	325	200	155	56	8	40	8	25	175	55	40	87.5	87.5
JUMBO 2	240	80	60	190	25	67.5	220	355	225	170	56	8	45	8	25	165	70	40	82.5	82.5
JUMBO 3	240	80	60	190	25	67.5	220	355	225	170	56	8	45	8	25	165	75	40	82.5	82.5
JUMBO 4	290	100	65	230	30	65	250	380	255	190	56	10	54	8	25	220	100	50	106	114
JUMBO 5	360	135	75	290	35	100	300	500	305	230	90	14	80	8	30	266	120	60	133	133

Dimensions [mm]																		
Size	D <sub>1</sub> <sup>2)</sup>	D <sub>2</sub>	D <sub>4</sub> TR	D <sub>4</sub> KGS	D <sub>5</sub>	D <sub>6</sub>	D <sub>7</sub>	D <sub>8</sub>	D <sub>9</sub> x b <sub>6</sub> <sup>5)</sup>	R(TK) <sup>6)</sup>	E <sub>1</sub> <sup>3)</sup>	E <sub>2</sub> <sup>3)</sup>	F <sub>1</sub> <sup>3)4)</sup>	F <sub>2</sub> <sup>3)4)</sup>	F <sub>3</sub> <sup>3)4)</sup>	F <sub>4</sub> <sup>3)4)</sup>	G <sup>7)</sup>	H <sup>7)</sup>
MULI 0	9 x 20	8	14 x 4	1205	26	M6	—	—	M5 x 3,5	24 (34)	12/10	35/42	48/40	28/24	38/34	6/4.5	—	—
MULI 1	10 x 21.5	12	18 x 4	1605	29.6	M8	28	12	M5 x 8	32(45.25)	12/12	44/44	48/48	28/28	38/38	6/5.5	—	—
MULI 2	14 x 25	15	20 x 4	2005	38.7	M8	35	15	M6 x 9	35(49.5)	12/12	44/44	55/55	32/32	45/45	7/7	—	—
MULI 3	16 x 42.5	20	30 x 6	2505	46	M10	35	17	M8 x 10	44(62.2)	14/14	46/46	62/62	38/38	50/50	7/7	—	—
MULI 4	20 x 45	25	40 x 7	4005/4010	60	M12	52	25	M10 x 14	55(77.8)	16/16	73/59	95/80	63/53	78/68	9/7	—	—
MULI 5	25 x 65	40	55 x 9	5010	85	M20	52	28	M12 x 16	60(84.85)	18/18	97/97	110/110	72/72	90/90	11/11	—	—
JUMBO 1	25 x 62.5	45	60x9	—	90	M24	52	28	M12 x 16	60(84.85)	20	99	125	85	105	11	—	—
JUMBO 2	30 x 65	55	70x10	—	105	M30	58	32	M12 x 18	(80)	30	100	180	95	140	17	—	—
JUMBO 3	30 x 65	60	80x10	8010	120	M30	58	32	M12 x 18	(80)	30/22	110/101	190/145	105/105	150/125	17/14	—	—
JUMBO 4	35 x 62.5	80	100x10	—	145	M36	85	40	—	—	35	130	240	130	185	25	145	50
JUMBO 5	48 x 97.5	95	120x14	—	170	M42	90	50	—	—	40	160	300	160	230	28	170	60

Note: Subject to change without prior notice.

<sup>1)</sup> Dimension A1 for Muli 0–2 to DIN 1688-T1/GTA 16, from MULI3 to DIN 1685 GTB 18

<sup>2)</sup> Diameter and length to shoulder

<sup>3)</sup> The first values in the table apply to the trapezoidal nut EFM. For dimension 4010 the first values in the table are valid!

<sup>4)</sup> The second values in the table apply to the flanged ball nut KGF

<sup>5)</sup> JUMBO 2 + 3 only 3 holes; JUMBO 4 + 5 without holes.

<sup>6)</sup> JUMBO 4 + 5 holes upon request, only.

<sup>7)</sup> JUMBO 4 + 5 screw exit on side E, bearing cover on side F.

## Accessories

### Top plate BP

Screwed onto the mounting thread of the jack screw and protected against rotation.

Standard: Hole-pattern BP symmetrically to screw jack housing.

Note: Please specify alignment at version V.

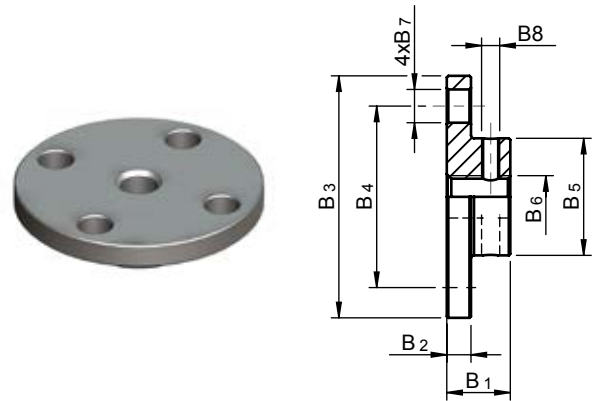

Dimensions [mm]								
	B <sub>1</sub>	B <sub>2</sub>	B <sub>3</sub>	B <sub>4</sub>	B <sub>5</sub>	B <sub>6</sub>	B <sub>7</sub>	B <sub>8</sub>
BP MULI 0	16	6	50	40	26	M8	7	M4
BP MULI 1	20	7	65	48	29,3	M12	9	M5
BP MULI 2	21	8	80	60	38,7	M14	11	M6
BP MULI 3	23	10	90	67	46	M20	11	M8
BP MULI 4	30	15	110	85	60	M30	13	M8
BP MULI 5	50	20	150	117	85	M36	17	M10
BP JUMBO 1	50	25	170	130	90	M48x2	21	M10
BP JUMBO 2	60	30	200	155	105	M56x2	25	M12
BP JUMBO 3	60	30	220	170	120	M64x3	25	M12
BP JUMBO 4	80	40	260	205	145	M72x3	32	M12
BP JUMBO 5	120	40	310	240	170	M100x3	38	M12

# Accessories

## Fork end GA

Screwed onto the mounting thread of the travelling screw and protected against rotation. Supplied with split pins and collar pins. Galvanized.

Standard: Pin mounted parallel to the drive shaft.

Note: Please specify alignment at version V.

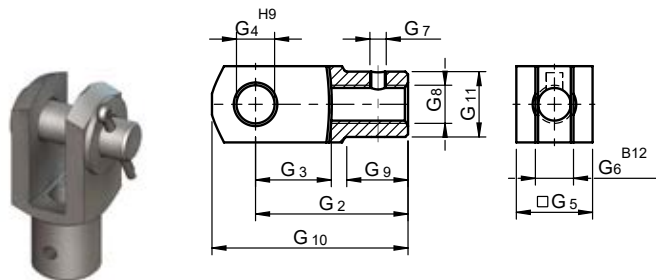

Dimensions [mm]										
	G <sub>2</sub>	G <sub>3</sub>	G <sub>4</sub>	G <sub>5</sub>	G <sub>6</sub>	G <sub>7</sub>	G <sub>8</sub>	G <sub>9</sub>	G <sub>10</sub>	G <sub>11</sub>
GA MULI 0	32	16	8	16	8	M4	M8	12	42	14
GA MULI 1	48	24	12	24	12	M5	M12	18	62	20
GA MULI 2	56	28	14	28	14	M6	M14	22	72	24,5
GA MULI 3	80	40	20	40	20	M8	M20	30	105	34
GA MULI 4	120	60	30	60	30	M8	M30	43	160	52
GA MULI 5	144	72	35	70	35	M10	M36	54	188	60

## Clevis end GK

Screwed onto the mounting thread of the jack screw and protected against rotation.

Standard: Clevis hole parallel to the drive shaft.

Note: Please specify alignment at version V.

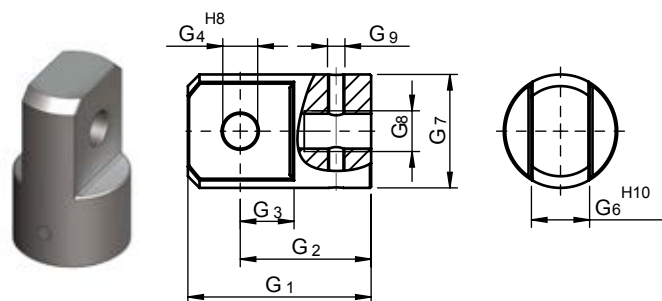

Dimensions [mm]								
	G <sub>1</sub>	G <sub>2</sub>	G <sub>3</sub>	G <sub>4</sub>	G <sub>6</sub>	G <sub>7</sub>	G <sub>8</sub>	G <sub>9</sub>
GK MULI 0	40	30	20	10	12	25	M8	M4
GK MULI 1	55	40	15	10	15	30	M12	M5
GK MULI 2	63	45	18	12	20	39	M14	M6
GK MULI 3	78	53	20	16	30	45	M20	M8
GK MULI 4	100	70	30	20	35	60	M30	M8
GK MULI 5	130	97	33	22	40	85	M36	M10
GK JUMBO 1	120	75	45	40	60	90	M48x2	M10
GK JUMBO 2	130	90	50	50	70	105	M56x2	M12
GK JUMBO 3	155	105	60	60	80	120	M64x3	M12
GK JUMBO 4	220	135	85	80	110	145	M72x3	M12
GK JUMBO 5	300	200	100	90	120	170	M100x3	M12

Spherical clevis ends KGK upon request

# Accessories

## Protection Bellow F

Bellow cover for protection against external influences. Suitable for horizontal or vertical installation.

Material: PVC-coated polyester, stitched construction. Temperature range -30 °C to 70 °C.

Calculation: For each 150 mm of open length up to 1800 mm allow 8 mm when calculating the closed length. Allow 10 mm for each 150 mm over 1800 mm. The calculated length is added to value C3 (see page 34-35) as the screw extension. Diameter F2 may differ on the opposite side, depending on the attachment fitted.

Installation: Installation position must be specified: horizontal installation requires internal support washers; in the case of vertical installation, bellows over 2000 mm have textile strips. Attachment is by hose clamps.

Note: Version R (rotating screw) includes one bellow. Second bellow with attachment adapter can be supplied when specifying the collar diameter and installation details. The mounting of the second bellow at the end of the screw is carried out by the customer.

Please always specify the flange direction of the nut.

**N/V-Version**

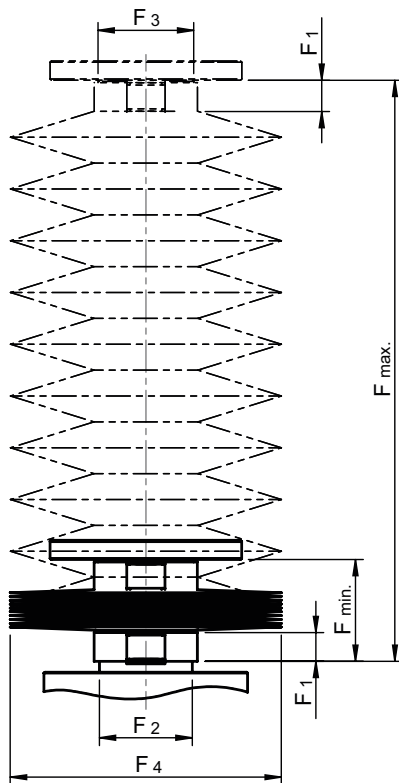

**R-Version**

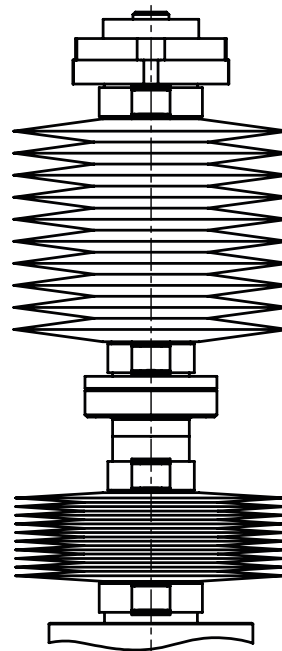



# Accessories

Dimensions [mm]					
Size		F <sub>1</sub>	F <sub>2</sub>	F <sub>3</sub>	F <sub>4</sub>
F MULIO	N/V TGS <sup>1)</sup>	12	26	30	101
	N/V KGS <sup>1)</sup>	12	36	30	101
	R TGS <sup>1)</sup>	12	26	28	101
	R KGS <sup>1)</sup>	12	26	24	101
F MULI 1	N/V TGS <sup>1)</sup>	12	30	30	101
	N/V KGS <sup>1)</sup>	12	48	30	101
	R	12	30	28	101
F MULI 2	N/V TGS <sup>1)</sup>	12	39	39	113
	N/V KGS <sup>1)</sup>	12	61	39	113
	R	12	39	32	113
F MULI 3	N/V	20	46	46	127
	R	20	46	38	127
F MULI 4	N/V	20	60	60	140
	R TGS <sup>1)</sup> /KGS <sup>1)</sup> -4010	20	60	63	140
	R KGS <sup>1)</sup> -4005	20	60	53	140
F MULI 5	N/V	20	85	85	152
	R	20	85	72	152
F JUMBO 1	N/V	20	90	90	165
	R	20	90	85	165
F JUMBO 2	N/V	20	105	105	175
	R	20	105	95	175
F JUMBO 3	N/V	20	120	120	191
	R	20	120	105	191
F JUMBO 4	N/V	20	145	145	201
	R	20	145	130	201
F JUMBO 5	N/V	20	170	170	245
	R	20	170	160	245

<sup>1)</sup>TGS = Trapezoidal screw  
KGS = Ball screw

### up to 1800 mm stroke:

$$F_{\min} = 2 \times F_1 + \text{Rounding (stroke/150)} \times 8 [\text{mm}]$$

### more than 1800 mm stroke:

$$F_{\min} = 2 \times F_1 + \text{Rounding (stroke/150)} \times 10 [\text{mm}]$$

$$F_{\max} = F_{\min} + \text{stroke}$$

# Accessories

## Adapter for attaching a second bellow

For version R only

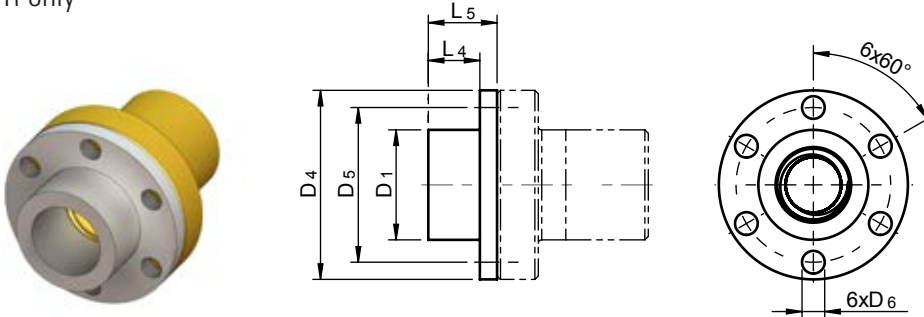

Dimensions							
Size	Type/Size	Dimensions [mm]					
		D <sub>1</sub>	D <sub>4</sub>	D <sub>5</sub>	D <sub>6</sub>	L <sub>4</sub>	L <sub>5</sub>
MULI 0	TGM - EFM Tr14x4	28	48	38	6	15	20
MULI 1	TGM - EFM Tr18x4	28	48	38	6	15	20
MULI 2	TGM - EFM Tr20x4	32	55	45	7	15	20
MULI 3	TGM - EFM Tr30x6	38	62	50	7	20	25
MULI 4	TGM - EFM Tr40x7	63	95	78	9	20	25
MULI 5	TGM - EFM Tr55x9	72	110	90	11	20	25
JUMBO 1	TGM - EFM Tr60x9	85	125	105	11	20	25
JUMBO 2	TGM - EFM Tr70x10	95	180	140	17	20	25
JUMBO 3	TGM - EFM Tr80x10	105	190	150	17	20	25
JUMBO 4	TGM - EFM Tr100x10	130	240	185	25	25	30
JUMBO 5	TGM - EFM Tr120x14	130	300	230	28	30	35

## Spiral spring band cover SF

Spiral spring band cover for protection against external influences. Suitable for horizontal or vertical installation.

Material: hardened spring band steel (stainless steel upon request)

Note: Delivery with 1 pc. centering bushing and/or centering adapter for the flanged nut with version R.

Please always specify the flange direction of the nut.

See next page for dimensions.

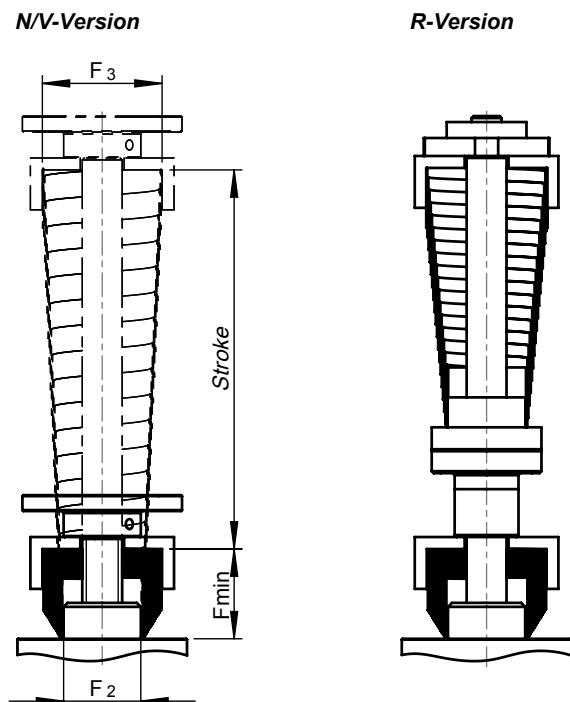

# Accessories

Dimensions									
Size		Dimensions [mm]			External-Ø				
		F <sub>2</sub>	Stroke	F <sub>min.</sub>					
MULI 0 MULI 1	SF	30	150	30	39				
			200		42				
			250		44				
			300		46				
			350		49				
			400		50				
			450		53				
			500	40	55				
			550		58				
			600		60				
			650		60				
			700		64				
			MULI 2		SF	40	150	30	51
							250		56
350	60								
400	40	63							
450	30	64							
500	40	65							
550		68							
650		65							
750	50	69							
850	71								
900	60	70							
1100	75	78							
1300		84							
1500		90							
1600	100	81							
1800		82							
2000		86							
2200	120	90							
MULI 3	SF	50	150	30	63				
			250		68				
			350		73				
			450	50	70				
			550		73				
			600		72				
			650	50	73				
			750	60	80				
			900		81				
			1100		90				
			1200	75	94				
			1300	100	80				
			1500		88				
			1600		89				
			1700	120	91				
			1800		94				
			1900		96				
			2100	120	100				
			2300		105				
			2500		115				
			2800	150	118				
			3000		123				
			3250		180				
			3500	200	134				

Dimensions					
Size		Dimensions [mm]			External-Ø
		F <sub>2</sub>	Stroke	F <sub>min.</sub>	
MULI 4	SF	65	100	30	76
			150		78
			250	50	76
			350		84
			450		88
			500	60	86
			550	50	92
			650	60	93
			700		94
			750		95
			800		98
			900		103
			1100	75	107
			1300		111
			1500		115
			1700	100	113
			1800		119
			1900	120	109
			2100		113
			2300		118
2500	128				
2800	134				
3000	150	142			
3250	180	145			
3500	2000	148			
MULI 5	SF	90	150	50	112
			250		116
			350		121
			450	75	125
			550		119
			650		124
			750	100	128
			900		133
			1100		126
			1300	120	132
			1500		144
			1800		138
			2000	150	148
			2300		154
			2600		159
			2800	200	160
			3000		166
			3250		166
3500	200	170			
3700		173			
4000		182			

Internal-Ø of the centering bushing = F<sub>3</sub> + 4 mm

# Accessories

## Trapezoidal thread nut, complete bronze TGM-EFM

For motion systems in continuous operation with particularly favorable wear characteristics. Suitable as safety nut.

EFM can be fitted with the KON and KAR adapters (see pages 47–48).

Material: 2.1090 (G-CuSn 7Zn Pb (Rg7)).

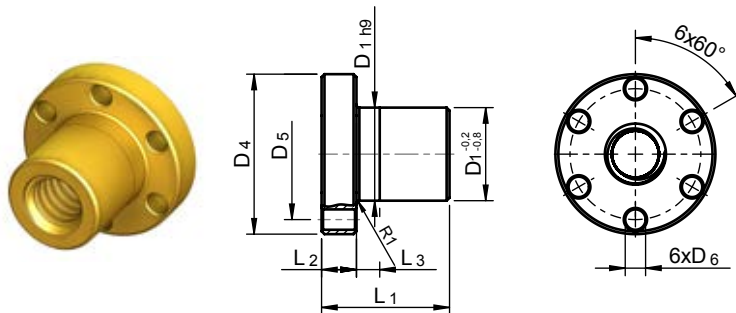

Dimensions [mm]										
Size	Type/Size	ID number	Bearing length ratio [N/mm <sup>2</sup> ]	D <sub>1</sub>	D <sub>4</sub>	D <sub>5</sub>	D <sub>6</sub>	L <sub>1</sub>	L <sub>2</sub>	L <sub>3</sub>
MULI 0	TGM - EFM Tr14x4	0110230054	450	28	48	38	6	35	12	8
MULI 1	TGM - EFM Tr18x4	0110064	770	28	48	38	6	44	12	8
MULI 2	TGM - EFM Tr20x4	0110067	870	32	55	45	7	44	12	8
MULI 3	TGM - EFM Tr30x6	0110073	1350	38	62	50	7	46	14	8
MULI 4	TGM - EFM Tr40x7	0110079	2930	63	95	78	9	73	16	10
MULI 5	TGM - EFM Tr55x9	0110085	5350	72	110	90	11	97	18	10
JUMBO 1	TGM - EFM Tr60x9	0110086	6040	85	125	105	11	99	20	10
JUMBO 2	TGM - EFM Tr70x10	0110726	8250	95	180	140	17	100	30	16
JUMBO 3	TGM - EFM Tr80x10	0110716	10890	105	190	150	17	110	30	16
JUMBO 4	TGM - EFM Tr100x10	0110727	13530	130	240	185	25	130	35	16
JUMBO 5	TGM - EFM Tr120x14	0110728	19800	130	300	230	28	160	40	20

## Material Properties

- 0.2 % yield point R<sub>p0.2</sub>: 120 N/mm<sup>2</sup>
- Tensile strength R<sub>m</sub> (δB): 240 N/mm<sup>2</sup>
- Elongation at fracture A<sub>5 min.</sub>: 15 %
- Brinell hardness HB 10/1000: 65
- Density: 8.8 kg/dm<sup>3</sup>
- Modulus of elasticity: 90000 N/mm<sup>2</sup>
- pv factor: 300 N/mm<sup>2</sup> · m/min

pv factor	
Material	pv factor [N/mm <sup>2</sup> · m/min]
G-CuSn 7 ZnPb (Rg 7)	300
P <sub>p</sub> factor	
Material	P <sub>p</sub> factor [N/mm <sup>2</sup> ]
G-CuSn 7 ZnPb (Rg7)	10 - 20

# Accessories

## Flanged ball nut KGF-N

Flanged ball nut with mounting and lubrication holes and with profiled gaskets (reduces lubricant leakage and prevents ingress of dirt particles) for ball screw KGS.

Material: 1.7131 (ESP 65) or 1.3505 (100Cr6).

Note: For KGS version, please specify installation direction of nut.

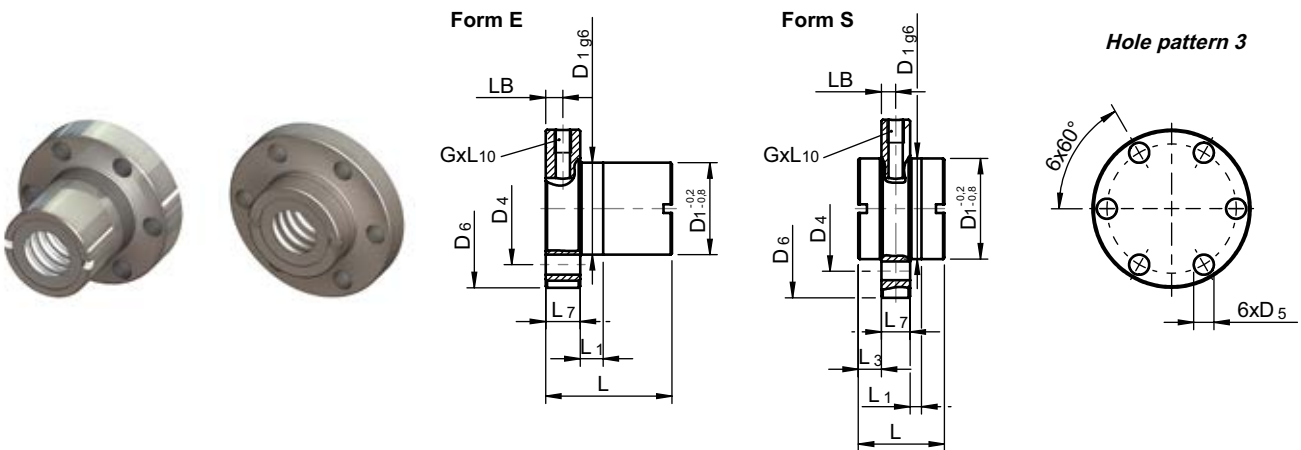

Dimensions																			
Size	Type/Size	ID number	Form	Hole pattern	Dimensions [mm]											Axial backlash max. [mm]	No. of circuits	Load rating [kN]	
					D <sub>1</sub>	D <sub>4</sub>	D <sub>5</sub>	D <sub>6</sub>	L <sub>1</sub>	L	L <sub>3</sub>	L <sub>7</sub>	L <sub>10</sub>	LB	G			C <sub>am</sub>	C <sub>0am</sub>
MULI 0	KGF-N-1205-RH-K-00	-	E	3	24	34	4,5	40	6	42	-	10	8	6	M6x1	0,08	3	3,9	6,3
MULI 1	KGF-N-1605-RH-E-EE	0215200047	E	3	28	38	5,5	48	8	44	-	12	8	6	M6x1	0,08	3	9,3	13,1
MULI 2	KGF-N-2005-RH-E-EE	0215200049	E	3	32	45	7	55	8	44	-	12	8	6	M6x1	0,08	3	10,5	16,6
	KGF-N-2020-RH-D-EE	0215200181	S	3	35	50	7	62	4	30	8	10	8	5	M6x1	0,15	4	11,6	18,4
MULI 3	KGF-N-2050-RH-D-EE	0215200211	S	3	35	50	7	62	10	56	9	10	8	5	M6x1	0,15	5	13,0	24,6
	KGF-N-2505-RH-E-EE	0215200050	E	3	38	50	7	62	8	46	-	14	8	7	M6x1	0,08	3	12,3	22,5
	KGF-N-3205-RH-E-EE	0215200053	E	3	45	58	7	70	10	59	-	16	8	8	M6x1	0,08	5	21,5	49,3
	KGF-N-3210-RH-E-EE	0215200075	E	3	53	68	7	80	10	73	-	16	8	8	M8x1	0,08	3	33,4	54,5
MULI 4	KGF-N-3240-RH-D-EE	0215200210	S	3	53	68	7	80	14	45	7,5	16	10	8	M6x1	0,15	4	14,9	32,4
	KGF-N-4005-RH-E-EE	0215200055	E	3	53	68	7	80	10	59	-	16	8	8	M6x1	0,08	5	23,8	63,1
MULI 5	KGF-N-4010-RH-E-EE	0215200353	E	3	63	78	9	95	10	73	-	16	8	8	M8x1	0,08	3	38,0	69,1
	KGF-N-5010-RH-E-EE	0215200041	E	3	72	90	11	110	10	97	-	18	8	9	M8x1	0,08	5	68,7	155,8
JUMBO 3	KGF-N-6310-RH-E-EE	0215200058	E	3	85	105	11	125	10	99	-	20	8	10	M8x1	0,08	5	76,0	197,0
	KGF-N-8010-RH-E-EE	0215200028	E	3	105	125	14	145	10	101	-	22	8	11	M8x1	0,08	5	86,2	262,4

# Accessories

## Flanged ball nut KGF-D

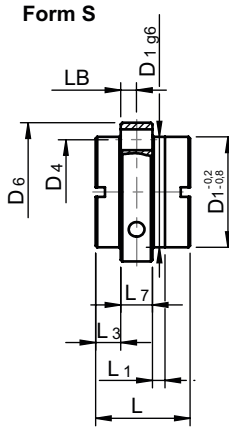
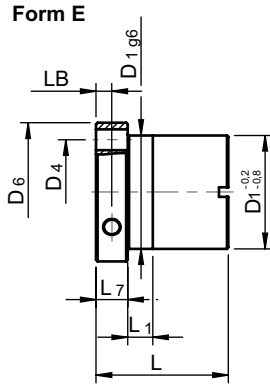

Hole pattern 1 according to DIN 69051

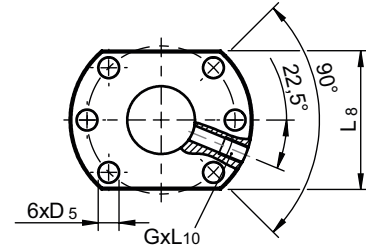

Hole pattern 2 according to DIN 69051

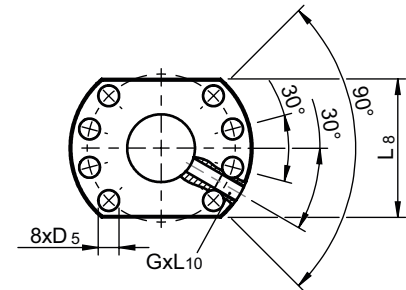

Dimensions																				
Size	Type/Size	ID number	Form	Hole pattern	Dimensions [mm]												Axial backlash max. [mm]	No. of circuits	Load Rating [kN]	
					D <sub>1</sub>	D <sub>4</sub>	D <sub>5</sub>	D <sub>6</sub>	L <sub>1</sub>	L	L <sub>3</sub>	L <sub>7</sub>	L <sub>8</sub>	L <sub>10</sub>	LB	G			C <sub>am</sub>	C <sub>0am</sub>
MULI 1	KGF-D-1605-RH-E-EE	0215200048	E	1	28	38	5,5	48	10	42	—	10	40	10	5	M6x1	0,08	3	9,3	13,1
	KGF-D-1610-RH-K-EE	0215200168	E	1	28	38	5,5	48	10	55	—	10	40	10	5	M6x1	0,08	6	15,4	26,5
MULI 2	KGF-D-2005-RH-K-EE	0215200185	E	1	36	47	6,6	58	10	42	—	10	44	10	5	M6x1	0,08	3	10,5	16,6
MULI 3	KGF-D-2505-RH-E-EE	0215200051	E	1	40	51	6,6	62	10	42	—	10	48	10	5	M6x1	0,08	3	12,3	22,5
	KGF-D-2510-RH-K-EE	0215200175	E	1	40	51	6,6	62	16	55	—	10	48	10	5	M6x1	0,08	3	13,2	25,3
	KGF-D-2520-RH-D-EE	0215200200	S	1	40	51	6,6	62	4	35	10,5	10	48	8	5	M6x1	0,15	4	13	23,3
	KGF-D-2525-RH-D-EE <sup>1)</sup>	0215200201	S	1	40	51	6,6	62	9	35	8	10	— <sup>1)</sup>	8	5	M6x1	0,08	5	16,7	32,3
	KGF-D-2550-RH-D-EE	0215200195	S	1	40	51	6,6	62	10	58	10	10	48	8	5	M6x1	0,15	5	15,4	31,7
	KGF-D-3205-RH-E-EE	0215200054	E	1	50	65	9	80	10	55	—	12	62	10	6	M6x1	0,08	5	21,5	49,3
	KGF-D-3210-RH-E-EE	0215200087	E	1	53 <sup>2)</sup>	65	9	80	16	69	—	12	62	10	6	M8x1	0,08	3	33,4	54,5
KGF-D-3220-RH-K-EE	0215200191	E	1	53 <sup>2)</sup>	65	9	80	16	80	—	12	62	10	6	M6x1	0,08	4	29,7	59,8	
MULI 4	KGF-D-4005-RH-E-EE	0215200056	E	2	63	78	9	93	10	57	—	14	70	10	7	M6x1	0,08	5	23,8	63,1
	KGF-D-4010-RH-E-EE	0215200356	E	2	63	78	9	93	16	71	—	14	70	10	7	M8x1	0,08	3	38	69,1
	KGF-D-4020-RH-K-EE	0215200206	E	2	63	78	9	93	16	80	—	14	70	10	7	M8x1	0,08	4	33,3	76,1
	KGF-D-4040-RH-D-EE <sup>1)</sup>	0215200199	S	2	63	78	9	93	16	85	7,5	14	— <sup>1)</sup>	10	7	M8x1	0,15	8	35	101,9
MULI 5	KGF-D-5010-RH-E-EE	0215200074	E	2	75	93	11	110	16	95	—	16	85	10	8	M8x1	0,08	5	68,7	155,8
	KGF-D-5020-RH-K-EE	0215200212	E	2	85 <sup>2)</sup>	103 <sup>2)</sup>	11	125	22	95	—	18	95	10	9	M8x1	0,08	4	60	136,3

<sup>1)</sup> Round flange

<sup>2)</sup> Dimension does not comply with DIN 69051

# Accessories

## Universal joint adapter KAR

Universal joint adapter for trunnion mounting of flanged ball nut KGF and trapezoidal nut EFM.

Material: 1.0065 (St37) or 1.0507 (St52)

*Hole pattern 1 according to DIN 6905 Hole pattern 2 according to DIN 69051*

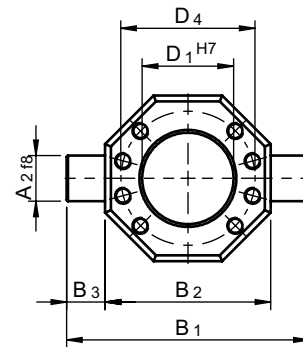
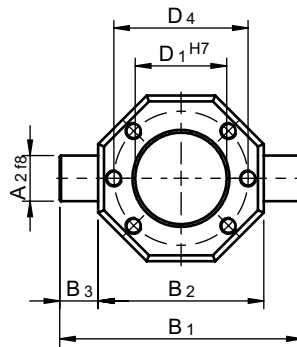

*Hole pattern 3*

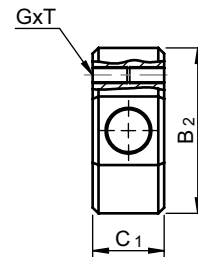
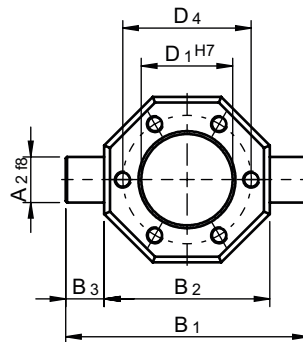

Dimensions												
Size	ID number	for KGF	for EFM	hole pattern	Dimensions [mm]							
					A <sub>2</sub>	B <sub>1</sub>	B <sub>2</sub>	B <sub>3</sub>	C <sub>1</sub>	D <sub>1</sub>	D <sub>4</sub>	GxT
KAR MULI 0	-		Tr14x4	3	12	70	50	10	20	28	38	M5x10
KAR MULI 0	-	KGF 1205		3	12	70	50	10	20	24	34	M4x8
KAR MULI 1	89022013	KGF-N 1605	Tr18x4	3	12	70	50	10	20	28	38	M5x10
KAR MULI 1	89022001	KGF-D 1610		1	12	70	50	10	20	28	38	M5x10
KAR MULI 2	89022014	KGF-N 2005	Tr20x4	3	16	85	58	13,5	25	32	45	M6x12
KAR MULI 2	89022015	KGF-N 2020 / 2050		3	18	95	65	15	25	35	50	M6x12
KAR MULI 3	89022016	KGF-N 2505	Tr30x6	3	18	95	65	15	25	38	50	M6x12
KAR MULI 3	89022003	KGF-D 2510 / 2520 / 2525 / 2550		1	18	95	65	15	25	40	51	M6x12
KAR MULI 3	89022017	KGF-N 3205		3	20	110	75	17,5	30	45	58	M6x12
KAR MULI 3	89022008	KGF-D 3220		1	25	125	85	20	30	53	65	M8x12
KAR MULI 3	89022018	KGF-N 3210 / 3240		3	25	125	85	20	30	53	68	M6x12
KAR MULI 4	89022018	KGF-N 4005		3	25	125	85	20	30	53	68	M6x12
KAR MULI 4	89022019	KGF-N 4010	Tr40x7	3	30	140	100	20	40	63	78	M8x14
KAR MULI 4	89022010	KGF-D 4020 / 4040		2	30	140	100	20	40	63	78	M8x14
KAR MULI 5	89022020	KGF-N 5010	Tr55x9	3	40	165	115	25	50	72	90	M10x16
KAR MULI 5	89022069	KGF-D 5020		2	40	180	130	25	50	85	103	M10x16
KAR JUMBO 1	89022021	KGF-N 6310	Tr60x9	3	40	180	130	25	50	85	105	M10x16
KAR JUMBO 2			Tr70x10	3	40	235	185	25	50	95	140	M16x20
KAR JUMBO 3	89022022	KGF-N 8010		3	50	200	150	25	60	105	125	M12x18

# Accessories

## Mounting adapter bracket KON

Adapter bracket for the radial mounting of flanged ball nut KGF and trapezoidal nut EFM.

Material: 1.0065 (St37) or 1.0507 (St52)



Hole pattern 1 according to DIN 69051

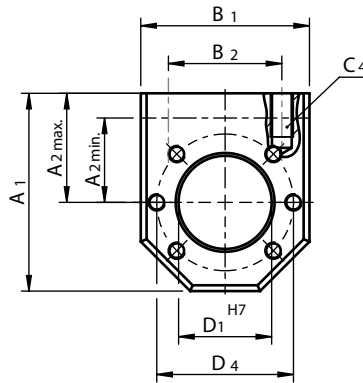

Hole pattern 2 according to DIN 69051

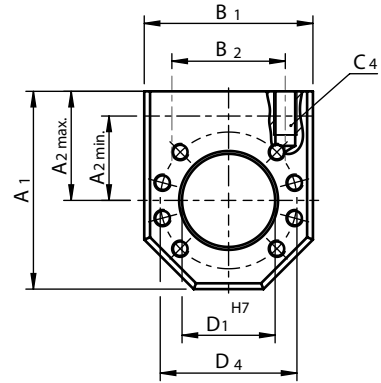

Hole pattern 3

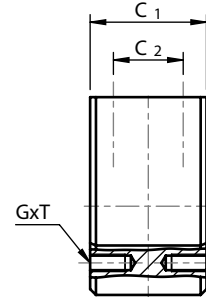
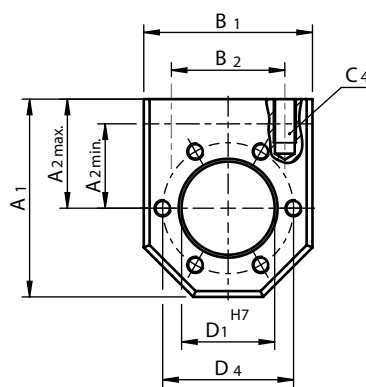

Dimensions																
Size	ID number	for KGF	for EFM	hole pattern	Dimensions [mm]											
					A <sub>1</sub>	A <sub>2 max</sub> <sup>1)</sup>	A <sub>2 min</sub>	B <sub>1</sub>	B <sub>2</sub>	C <sub>1</sub>	C <sub>2</sub>	C <sub>4</sub> <sup>1)</sup>	D <sub>1</sub>	D <sub>4</sub>	GxT	
KON MULI 0	-		Tr14x4	3	60	35	25	50	34	40	24	M8x15	28	38	M5x10	
KON MULI 0	-	KGF 1205		3	60	35	25	50	34	40	24	M8x15	24	34	M4x8	
KON MULI 1	89022032	KGF-N 1605	Tr18x4	3	60	35	25	50	34	40	24	M8x15	28	38	M5x10	
KON MULI 1	89022023	KGF-D 1610		1	60	35	25	50	34	40	24	M8x15	28	38	M5x10	
KON MULI 2	89022033	KGF-N 2005	Tr20x4	3	68	37,5	29	58	39	40	24	M8x15	32	45	M6x12	
KON MULI 2	89022035	KGF-N 2020 / 2050		3	75	42,5	32,5	65	49	40	24	M10x15	35	50	M6x12	
KON MULI 3	89022034	KGF-N 2505	Tr30x6	3	75	42,5	32,5	65	49	40	24	M10x15	38	50	M6x12	
KON MULI 3	89022025	KGF-D 2510 / 2520 / 2525 / 2550		1	75	42,5	32,5	65	49	40	24	M10x15	40	51	M6x12	
KON MULI 3	89022036	KGF-N 3205		3	82	45	37	75	54	50	30	M10x12	45	58	M6x12	
KON MULI 3	89022028	KGF-D 3220		1	92	50	40	85	60	50	30	M12x15	53	65	M8x12	
KON MULI 3	89022037	KGF-N 3210 / 3240		3	92	50	42	85	60	50	30	M10x15	53	68	M6x12	
KON MULI 4	89022037	KGF-N 4005		3	92	50	42	85	60	50	30	M12x15	53	68	M6x12	
KON MULI 4	89022038	KGF-N 4010	Tr40x7	3	120	70	50	100	76	65	41	M14x25	63	78	M8x14	
KON MULI 5	89022039	KGF-N 5010	Tr55x9	3	135	77,5	57,5	115	91	88	64	M16x25	72	90	M10x16	
KON MULI 5	89022072	KGF-D 5020		2	152	87,5	65	130	101	88	64	M16x30	85	103	M10x16	
KON JUMBO 1	89022040	KGF-N 6310	Tr60x9	3	152	87,5	65	130	101	88	64	M16x30	85	105	M10x16	
KON JUMBO 3	89022041	KGF-N 8010		3	172	97,5	-	150	121	88	64	M16x30	105	125	M12x18	

<sup>1)</sup> Standard = A<sub>2 max</sub> (delivery status)



## Accessories

### Mounting feet L

Supplied loose with mounting bolts for the screw jack. Burnished. Muli 0 – 2 with version N/V-KGS not on side F.

Standard mounting side: side E (see pages 34-35).

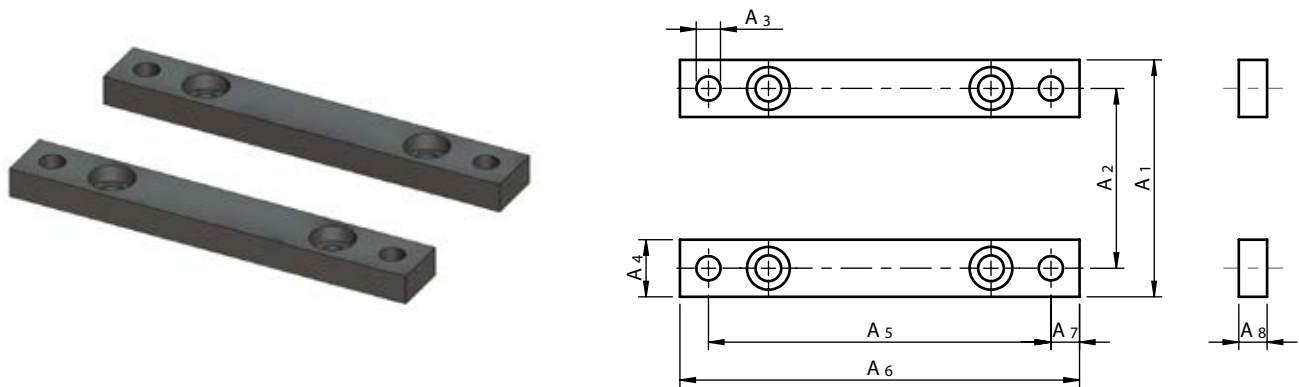

### Dimensions [mm]

Size	A <sub>1</sub>	A <sub>2</sub>	A <sub>3</sub>	A <sub>4</sub>	A <sub>5</sub>	A <sub>6</sub>	A <sub>7</sub>	A <sub>8</sub>
L MULI 0	53	38	6,5	15	75	90	7,5	10
L MULI 1	72	52	8,5	20	100	120	10	10
L MULI 2	85	63	8,5	20	120	140	10	10
L MULI 3	105	81	11	24	150	170	10	12
L MULI 4	145	115	13,5	30	204	230	13	16
L MULI 5	171	131	22	40	236	270	17	25
L JUMBO 1	205	155	26	50	250	290	20	30
L JUMBO 2	230	170	32	65	290	340	25	40
L JUMBO 3	230	170	32	65	290	340	25	40
L JUMBO 4	270	190	39	80	350	410	30	50
L JUMBO 5	330	230	45	100	430	500	35	60

# Accessories

## Universal joint adapter K, KZP, KB, KBP

Supplied loose with mounting bolts for the screw jack. Burnished.

Standard mounting side: side E. Please specify if mounting side F is required (see page 34-37).

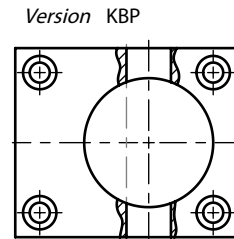
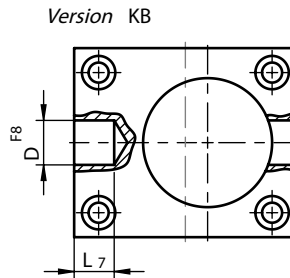
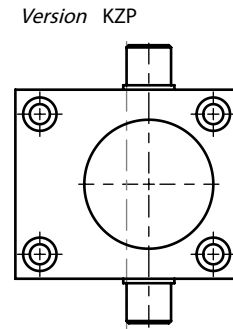
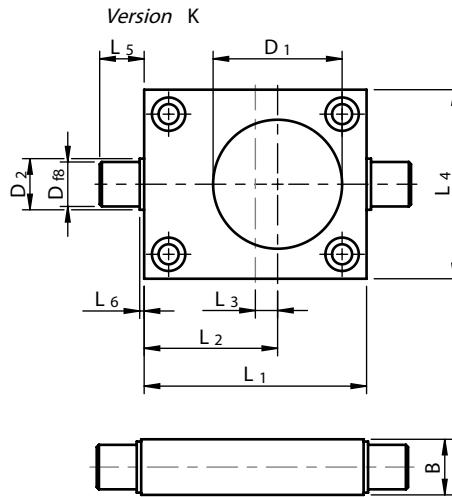

Dimensions [mm]												
Size	L <sub>1</sub>	L <sub>2</sub>	L <sub>3</sub>	L <sub>4</sub>	L <sub>5</sub>	L <sub>6</sub>	L <sub>7</sub>	D <sub>f8</sub>	D <sup>f8</sup>	D <sub>1</sub>	D <sub>2</sub>	B
K MULI 0	60	38	8	50	10	2	10	10	8	37	13	15
K MULI 1	80	49	9	72	15	2	13	15	15	44	18	20
K MULI 2	100	60	10	85	20	2	18	20	20	58	23	25
K MULI 3	130	76	11	105	20	2	18	25	22	72	28	30
K MULI 4	180	102	12	145	30	2	28	35	30	86	38	40
K MULI 5	200	117	17	165	35	2	33	45	40	115	48	50
K JUMBO 1	210	120	15	195	40	2	–	50	–	130	56	60
K JUMBO 2	240	140	20	220	45	2	–	70	–	170	76	80
K JUMBO 3	240	140	20	220	45	2	–	70	–	170	76	80
K JUMBO 4	290	165	20	250	60	2	–	80	–	160	88	90
K JUMBO 5	360	210	30	300	80	2	–	90	–	175	96	100

# Accessories

## Bearing units AFF for screw end



Hole pattern with 4 holes

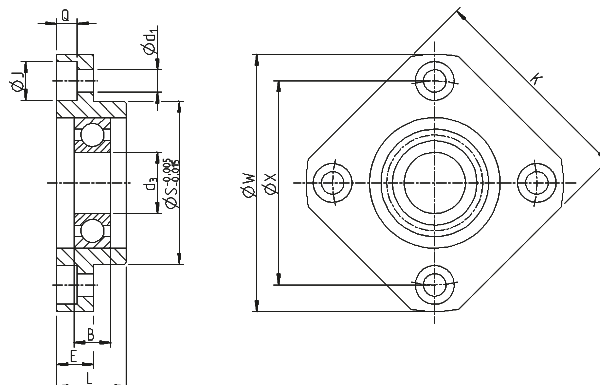

Hole pattern with 6 holes

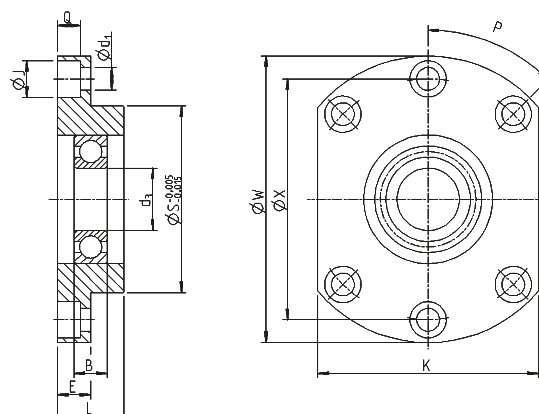

### For R-version!

We recommend a modified screw end for circlip DIN471 when screw jack is mounted inverse (screw pointing down).

## Dimensions

Size	Type/Size	Bearing type	Rated radial load [kN]	ID number	Dimensions [mm]										
					W	X	S	K	L	E	d <sub>1</sub>	d <sub>3</sub>	J	Q	P (°)
MULI 0	AFF 8 - Hole pattern 4	606	2,31	-	43	35	28	35	11	6	3,4	6 <sup>1)</sup>	6,5	4	90
	AFF 10 - Hole pattern 4	608	3,35	-	52	42	34	42	12	7	4,5	8	8	5	90
MULI 1	AFF 12 - Hole pattern 4	6000	4,65	89032455	54	44	36	44	15	8	4,5	10 <sup>2)</sup>	8	5	90
MULI 2	AFF 15 - Hole pattern 4	6002	5,70	89032456	63	50	40	52	17	9	5,5	15	9,5	6	90
MULI 3	AFF 20 - Hole pattern 4	6204	13,00	89032457	85	70	57	68	20	14	6,6	20	11	10	90
MULI 4	AFF 25 - Hole pattern 6	6205	14,30	89032436	122	100	80	92	30	15	11	25	17,5	11	45
MULI 5	AFF 40 - Hole pattern 6	6208	29,70	89032459	176	150	120	128	36	18	14	40	20	13	45

Note: Bearing units in different sizes and for other screw jack models upon request.

<sup>1)</sup> Modified screw end with D2 = Ø 6mm required  
<sup>2)</sup> Modified screw end with D2 = Ø 10mm required

# Accessories

## Bearing units BF for screw end

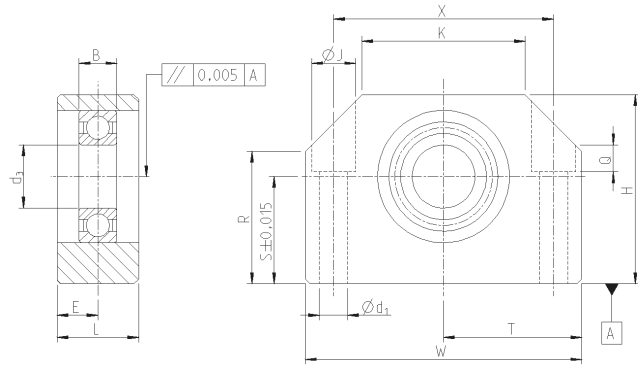

### For R-version!

We recommend a modified screw end for circlip DIN471 when screw jack is mounted inverse (screw pointing down).

Dimensions																	
Size	Type/Size	Bearing type	Rated radial load [kN]	ID number	Dimensions [mm]												
					W	H	S	R	T	X	K	d <sub>1</sub>	d <sub>3</sub>	J	Q	L	E
MULI 0 <sup>1)</sup>	BF 8	606	2,31	-	52	32	17	18,5	26	38	25	6,6	6 <sup>1)</sup>	11	6,5	20	10
	BF 10	608	3,35	-	60	39	22	26	30	46	34	6,6	8	11	6,5	20	10
MULI 1 <sup>2)</sup>	BF 12	6000	4,65	89032448	60	43	25	30	35	46	35	6,6	10 <sup>2)</sup>	11	6,5	20	10
MULI 2	BF 15	6002	5,70	89032438	70	48	28	33	43	54	40	6,6	15	11	6,5	20	10
MULI 3	BF 20	6004	9,55	89032441	88	60	34	42	44	70	52	9	20	14	8,5	26	13
MULI 4	BF 25	6205	14,30	89032449	106	80	48	59	53	85	64	11	25	17,5	11	30	15
MULI 5	BF 40	6208	29,70	89032450	160	110	60	90	80	130	100	18	40	26	17,5	37	37

Note: Bearing units in different sizes and for other screw jack models upon request.

<sup>1)</sup> Modified screw end with D2 = Ø 6 mm required

<sup>2)</sup> Modified screw end with D2 = Ø 10 mm required

## Accessories

### Handwheels HR

2-spoke handwheel of chill-cast light aluminium RN 9501, polished, with rotating conical handle of black plastic. Bore keyed to DIN 6885.

Note: Hand wheels must not be mounted on the drive shaft when not operating the screw jack. Separate storage is required!

Manual clamping plate KP available upon request.

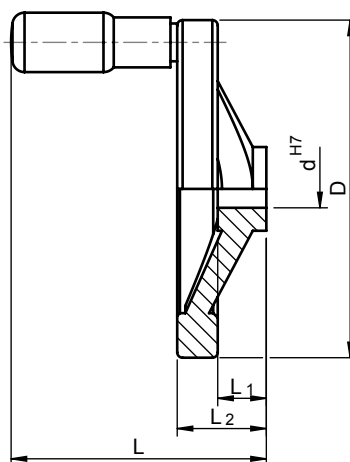

Dimensions						
Size	Type/Size	Dimensions [mm]				
		d	D	L	L <sub>1</sub>	L <sub>2</sub>
MULI 0	HR 80	9	80	81,5	16	29
	HR 100		100	85,5	17	33
	HR 125		125	94,5	18	36
MULI 1	HR 80	10	80	81,5	16	29
	HR 100		100	85,5	17	33
	HR 125		125	94,5	18	36
MULI 2	HR 80	14	80	81,5	16	29
	HR 100		100	85,5	17	33
	HR 125		125	94,5	18	36
	HR 140		140	97,5	19	39
	HR 160		160	107,5	20	40
MULI 3	HR 140	16	140	97,5	19	39
	HR 160		160	107,5	20	40
	HR 200		200	127,5	24	45
MULI 4	HR 200	20	200	127,5	24	45
	HR 250		250	154,5	28	50
MULI 5 / JUMBO 1	HR 250	25	250	154,5	28	50

# Accessories

## Safety nut SFM with wear indicator

### Version R

The safety nut is positioned below the travelling nut without axial load and is therefore not subjected to wear. The functioning of the safety nut is guaranteed only when installation and applied forces are as shown in the illustration (see right). As the travelling nut wears, the distance "X" (=1/4 of the lead of the thread of a single-thread screw) between the two nuts is decreasing, which provides a visual check of wear without the need for dismantling.

The travelling nut must be replaced when the distance "X" is decreased to 0 mm resp. the travelling nut is touching the safety nut, otherwise, safety cannot be guaranteed and people and property can be endangered.

Dimension X must be checked regularly.

The safety nut supports the load if the thread form of the travelling nut fails as a result of excessive wear (dirt, lubrication starvation, overheating, etc.). The safety nut can only be ordered together with the flanged nut.

### Version N and V

The design is similar to that for version R.

With increasing wear of the thread in the worm-wheel the distance "X" (=1/4 of the lead of the thread of a single-thread screw ) is decreasing between top edge of the safety nut and top edge of the bearing cover.

The worm-wheel nut must be replaced together with the safety nut when the distance "X" is decreased to 0 mm resp. the top edge of the safety nut is flush with the top edge of the bearing cover, otherwise, safety cannot be guaranteed and people and property can be endangered.

A visual check for wear is also possible in this case.

Inductive sensors upon request (subject to change of design).

Please specify the load direction when ordering.

# Accessories

## For R-version



## For N and V-version



## Load direction

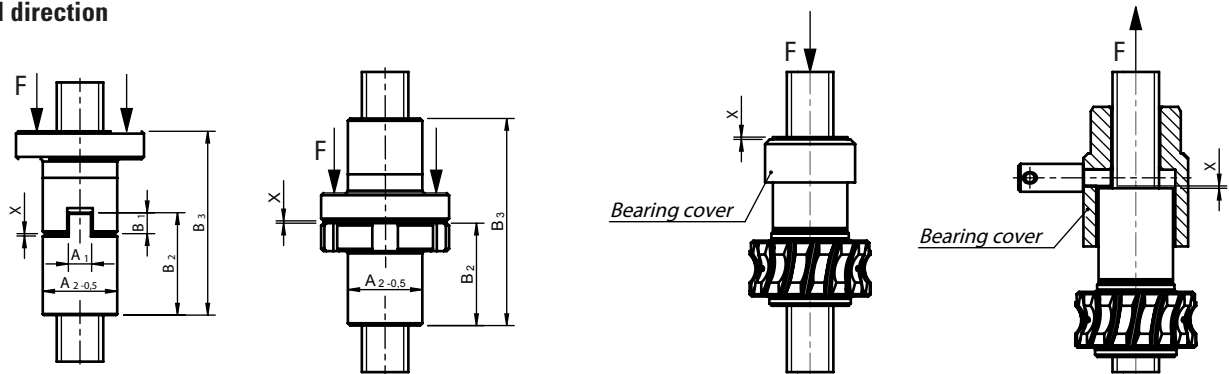

Dimensions							
Size	Version	Dimensions [mm]					
		A <sub>1</sub>	A <sub>2</sub>	B <sub>1</sub>	B <sub>2</sub>	B <sub>3</sub>	X
SFM MULI 1	R Standard	10	28	10	44	79	1
	R Flange to flange	–		–		90	
SFM MULI 2	R Standard	10	32	10	44	79	1
	R Flange to flange	–		–		90	
SFM MULI 3	R Standard	12	38	10	46	83,5	1,5
	R Flange to flange	–		–		93,5	
SFM MULI 4	R Standard	16	63	15	73	132,75	1,75
	R Flange to flange	–		–		147,75	
SFM MULI 5	R Standard	20	72	16	97	180,25	2,25
	R Flange to flange	–		–		196,25	
SFM JUMBO 1	R Standard	20	85	16	99	184,25	2,25
	R Flange to flange	–		–		200,25	
SFM JUMBO 2	R Standard	25	95	20	100	182,5	2,5
	R Flange to flange	–		–		202,5	
SFM JUMBO 3	R Standard	25	105	20	110	202,5	2,5
	R Flange to flange	–		–		222,5	
SFM JUMBO 4	R Standard	30	130	25	130	237,5	2,5
	RR Flange to flange	–		–		262,5	
SFM JUMBO 5	R Standard	40	160	25	160	298,5	3,5
	R Flange to flange	–		–		323,5	

<sup>1)</sup> For KGS upon request.  
<sup>2)</sup> Dimensions of flanged nuts see page 45.  
<sup>3)</sup> Version N/V SFM in the bearing cover (according to schemes). Dimension X remains the same.

# Accessories

## Limit switches with roller lever ES

Suitable for end-position shutoff.

Standard installation side B (see Fig.).

Note: If installation on other side, please specify.



Limit switches (fix / fix)

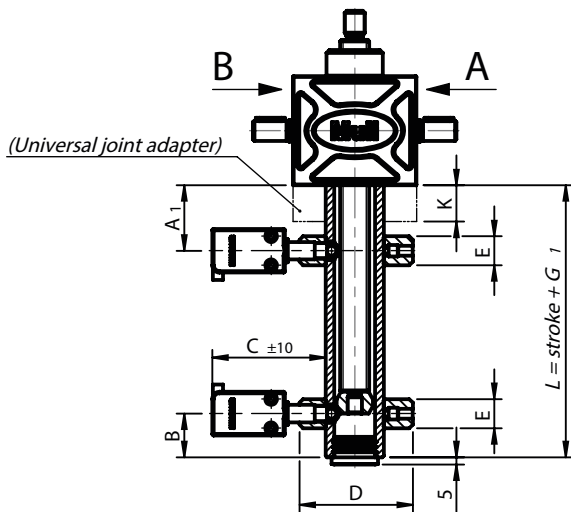

Limit switches (adjustable / adjustable)

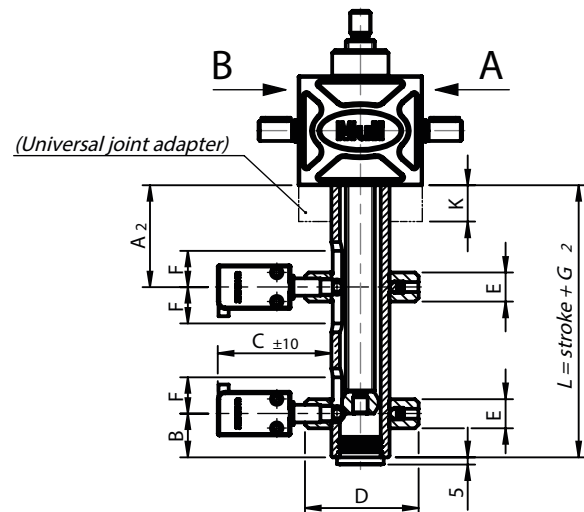

## Dimensions

Size	Dimensions [mm]									
	A <sub>1</sub>	A <sub>2</sub>	B	C	D	E	F	G <sub>1</sub>	G <sub>2</sub>	K
MULI 0	35	60	30	80	70	20	25	77	102	15
MULI 1	40	65	30	80	80	20	25	82	107	20
MULI 2	45	70	30	80	80	20	25	87	112	25
MULI 3	50	75	30	80	90	20	25	92	117	30
MULI 4	60	85	30	80	100	20	25	102	127	40
MULI 5	70	95	30	80	120	20	25	112	137	50
JUMBO 1	80	105	30	80	140	20	25	122	147	60
JUMBO 2	100	125	30	80	160	20	25	142	167	80
JUMBO 3	100	125	30	80	160	20	25	142	167	80
JUMBO 4	110	135	30	80	170	20	25	152	177	90
JUMBO 5	120	145	30	80	190	20	25	162	187	100



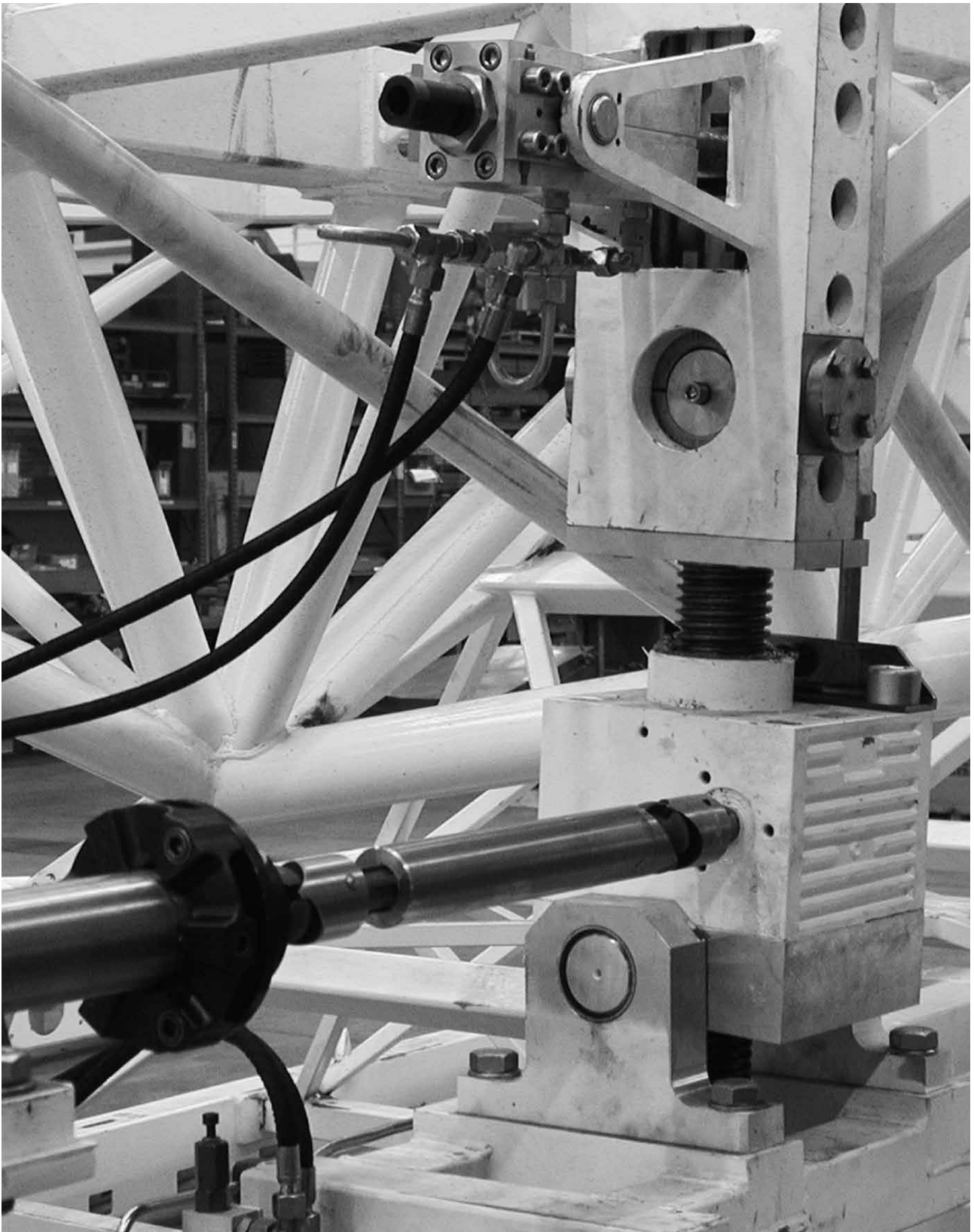

Loading a wing for final assembly at Airbus S.E.S. in Toulouse, France

## Drive Technology

### **Benefits using Thomson as your screw jack and motor supplier**

- Optimum price versus performance ratio.
- System application, screw jack and drive all perfectly matched from a single source.
- No hidden costs.
- One competent partner from start to finish.



## Drive Technology

### 3-phase motors DRS / DRE

3-phase 4-pole motors (1500 RPM) in totally enclosed fan-cooled designs in accordance with VDE 0530 Part 1.

Standard protection class: IP54. Temperature class B.

Notes: If the free shaft end of the motor is used as shaft for a slip-on emergency hand wheel, a device will be required which interrupts the power supply before the crank engages.

Motors with different speeds, other protection class, etc. upon request.

#### With flange mount - type FF, FL - B5/FT - B14

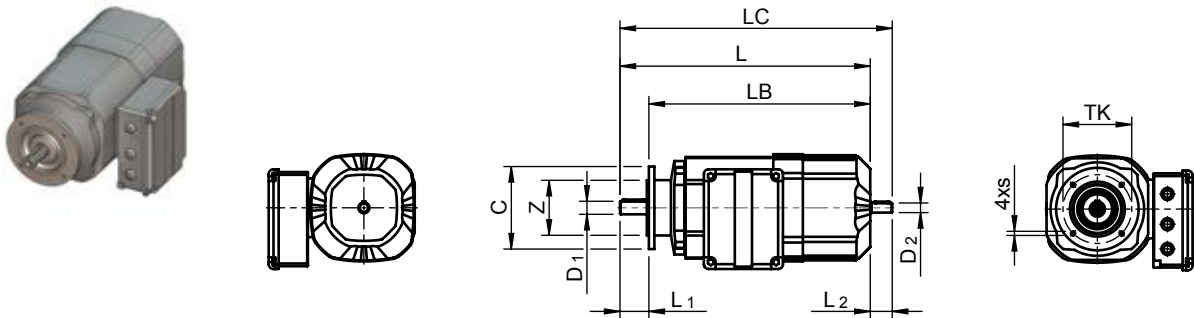

#### With foot mount - type FI - B3

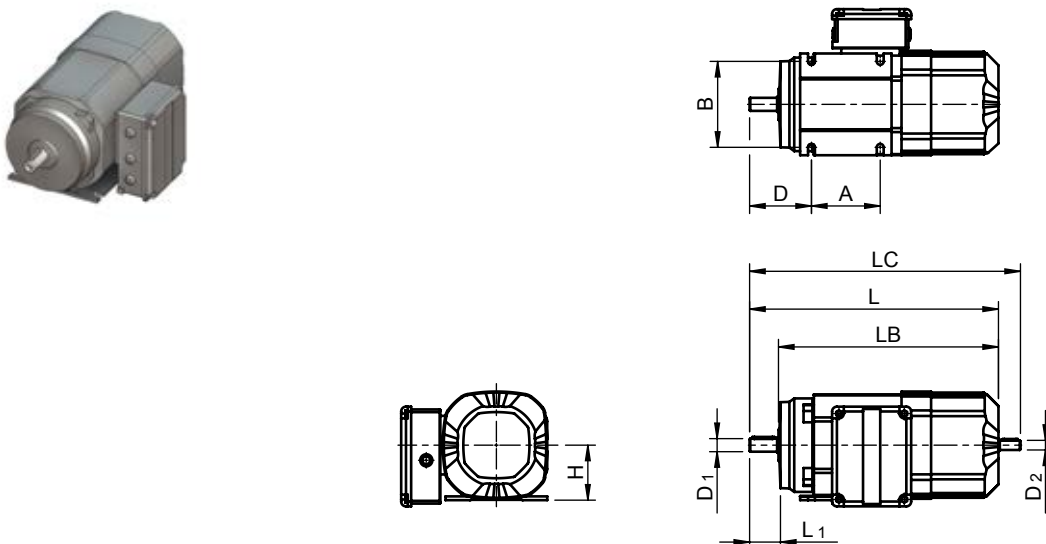

# Drive Technology

## 3-phase motors DRS / DRE

Specifications							
Size <sup>2)</sup>	Nominal torque M <sub>0</sub> [Nm]	Capacity P <sub>N</sub> [Nm]	Nominal speed n <sub>M</sub> [RPM]	Brake torque M <sub>BR</sub> [Nm]	Nominal current I <sub>N</sub> 400 V [A]	Weight <sup>1)</sup> [kg]	Type <sup>2)</sup>
DRS71S4	2.55	0.37	1380	5	1.14	10.2 (7.8)	B3 (FI)
							B14 (FT)
DRS71M4	3.80	0.55	1380	10	1.55	11.7 (9.1)	B3 (FI)
							B14 (FT)
DRE80M4	5	0.75	1435	10	1.68	17.3 (14.3)	B3 (FI)
							B14 (FT)
DRE90M4	7.40	1.10	1420	14	1.45	23.0 (18.4)	B3 (FI)
							B14 (FT)
DRE90L4	10	1.50	1430	20	3.35	26.0 (21.5)	B3 (FI)
							B14 (FT)
DRE100M4	14,7	2.20	1425	28	4,6	32.0 (26.0)	B3 (FI)
							B5 (FF)
DRE100LC4	19,7	3.00	1455	40	6,2	37.0 (31.0)	B3 (FI)
							B5 (FF)
DRE132S4	26	4.00	1460	55	8	55.0 (46.5)	B3 (FI)
							B5 (FF)

<sup>1)</sup> Standard motors = brake motors. The values in brackets refer to motors without brake.

<sup>2)</sup> Additional motor sizes and types upon request.

Dimensions														
Size	Dimensions [mm]													
	C	H	TK	Z	D1	L1	D2	L2	L <sup>1)</sup>	LB <sup>1)</sup>	LC <sup>1)</sup>	A	B	D
DRS71S4	-	71	-	-	14	30	11	25	296 (228)	264 (196)	321 (253)	90	112	75
	120	-	100	80						266 (198)		-	-	-
DRS71M4	-	71	-	-	19	40	11	25	331 (263)	289 (221)	356 (288)	100	125	90
	120	-	100	80						291 (223)		-	-	-
DRE80M4	-	80	-	-	19	40	14	32	393 (312)	351 (270)	425 (344)	100	125	90
	120	-	100	80						353 (272)		-	-	-
DRE90M4	-	90	-	-	24	50	14	32	409 (316)	357 (264)	441 (348)	125	140	106
	160	-	130	110						359 (272)		-	-	-
DRE90L4	-	90	-	-	24	50	14	32	429 (336)	377 (284)	461 (368)	125	140	106
	160	-	130	110						379 (336)		-	-	-
DRE100M4	-	100	-	-	28	60	14	32	469 (376)	407 (314)	501 (408)	140	160	123
	200	-	165	130						409 (316)		-	-	-
DRE100LC4	-	100	-	-	28	60	14	32	499 (406)	437 (344)	531 (438)	140	160	123
	200	-	165	130						439 (346)		-	-	-
DRE132S4	-	112	-	-	28	60	19	43,5	559 (447)	497 (385)	602.5 (490.5)	140	190	130
	250	-	215	180						499 (387)		-	-	-

## Drive Technology

### Servo motors AKM

Brushless AKM Servo motor with IEC flange, plain shaft, angular and rotatable connectors, 24 volt holding brake. Resolver, standard protection class IP65.



Specifications								
Size	Nominal torque $M_0$ [Nm]	Stall torque $M_0$ [Nm]	Brake torque $M_{BR}$ [Nm]	Nominal current $I_{0_{rms}}$ [A]	Voltage $U_n$ [V AC]	Nominal speed $n_n$ [RPM]	Input voltage brake $U_{BR}$ [VDC]	Weight [kg]
AKM22C	0.78	0.84	1.42	1.39	230	3500	24 ±10%	1.37
	0.68				400	8000		
AKM24C	1.32	1.38	1.42	1.42	230	2000	24 ±10%	1.93
	1.25				400	4500		
AKM32C	1.95	2.00	2.50	1.44	230	1500	24 ±10%	2.58
	1.86				400	3000		
AKM42E	3.12	3.42	6.00	2.74	230	1800	24 ±10%	4.02
	2.81				400	3500		
AKM44G	4.90	5.88	6.00	5.00	230	2000	24 ±10%	3.33
	3.76				400	4000		
AKM52K	6.80	8.60	14.50	9.30	230	3000	24 ±10%	6.90
	3.90				400	5500		
AKM53K	10.10	11.60	14.50	9.40	230	2000	24 ±10%	10.20
	7.65				400	4000		
AKM63M	14.30	17.00	25.00	13.80	230	2000	24 ±10%	26.00
	11.30				400	4000		
AKM65N	19.80	24.30	25.00	17.80	230	2000	24 ±10%	17.40
	16.00				400	3500		
AKM72P	23.80	29.40	53.00	18.70	230	1800	24 ±10%	21.80
	20.10				400	3000		
AKM73M	–	42.00	53.00	13.60	–	–	24 ±10%	28.80
	33.80				400	1500		
AKM74P	–	52.50	53.00	15.50	–	–	24 ±10%	35.70
	39.60				400	1800		

<sup>1)</sup> Standard motors = brake motors

# Drive Technology

## Servo motors AKM

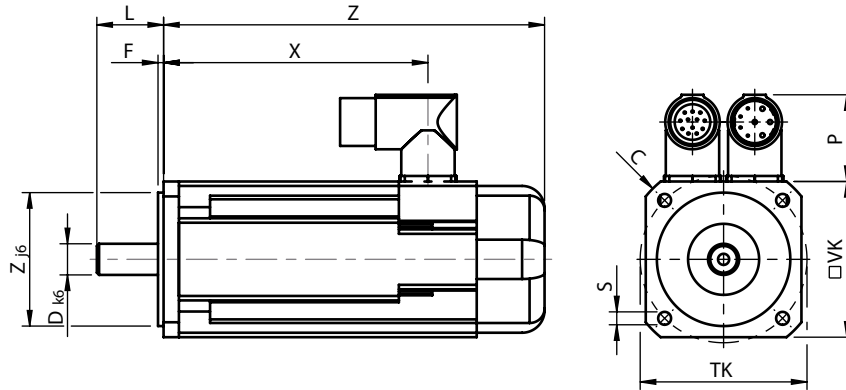

Dimensions														
Size	Servo amplifier Servostar	Motor cable with shielded wires	Resolver cable with shielded wires	Dimensions [mm]										
				VK	C	TK	Z	D	L	F	Z	X	S	P
AKM22C	341	4 x 1 + 2 x 0,75 mm <sup>2</sup>	4 x 2 x 0,25 mm <sup>2</sup>	58	40	63	40	9	20	2,5	148,5	95,1	Ø4,8	39
AKM24C	341	4 x 1 + 2 x 0,75 mm <sup>2</sup>	4 x 2 x 0,25 mm <sup>2</sup>	58	40	63	40	9	20	2,5	186,5	133,1	Ø4,8	39
AKM32C	341	4 x 1 + 2 x 0,75 mm <sup>2</sup>	4 x 2 x 0,25 mm <sup>2</sup>	70	90	75	60	14	30	2,5	171,3	118,9	Ø5,8	39
AKM42E	343	4 x 1 + 2 x 0,75 mm <sup>2</sup>	4 x 2 x 0,25 mm <sup>2</sup>	84	–	100	80	19	40	3	181,3	125,5	Ø7	39
AKM44G	346	4 x 1 + 2 x 0,75 mm <sup>2</sup>	4 x 2 x 0,25 mm <sup>2</sup>	84	–	100	80	19	40	3	239,3	183,4	Ø7	39
AKM52K	S712	4 x 2,5 + 2 x 1 mm <sup>2</sup>	4 x 2 x 0,25 mm <sup>2</sup>	108	–	130	110	24	50	3	203,5	136,3	Ø9	39
AKM53K	S712	4 x 2,5 + 2 x 1 mm <sup>2</sup>	4 x 2 x 0,25 mm <sup>2</sup>	108	–	130	110	24	50	3	234,5	167,3	Ø9	39
AKM63M	S724	4 x 2,5 + 2 x 1 mm <sup>2</sup>	4 x 2 x 0,25 mm <sup>2</sup>	138	–	135	130	32	58	3,5	225,7	155,5	Ø11	39
AKM65N	S724	4 x 2,5 + 2 x 1 mm <sup>2</sup>	4 x 2 x 0,25 mm <sup>2</sup>	138	–	135	130	32	58	3,5	275,7	205,5	Ø11	39
AKM72P	S724	4 x 2,5 + 2 x 1 mm <sup>2</sup>	4 x 2 x 0,25 mm <sup>2</sup>	188	–	215	180	38	80	4	234,5	164,5	Ø13,5	39
AKM73M	S724	4 x 2,5 + 2 x 1 mm <sup>2</sup>	4 x 2 x 0,25 mm <sup>2</sup>	188	–	215	180	38	80	4	268,5	198,5	Ø13,5	39
AKM74P	S724	4 x 2,5 + 2 x 1 mm <sup>2</sup>	4 x 2 x 0,25 mm <sup>2</sup>	188	–	215	180	38	80	4	302,5	232,5	Ø13,5	39

# Drive Technology

## Motor adapter flanges MG for 3-phase motors

Motor adapter flanges are used to mount motors to worm gear screw jacks and house the coupling for connecting the motor to the drive shaft. When ordering, please specify the side to which the motor adapter flange is to be attached (A or B).

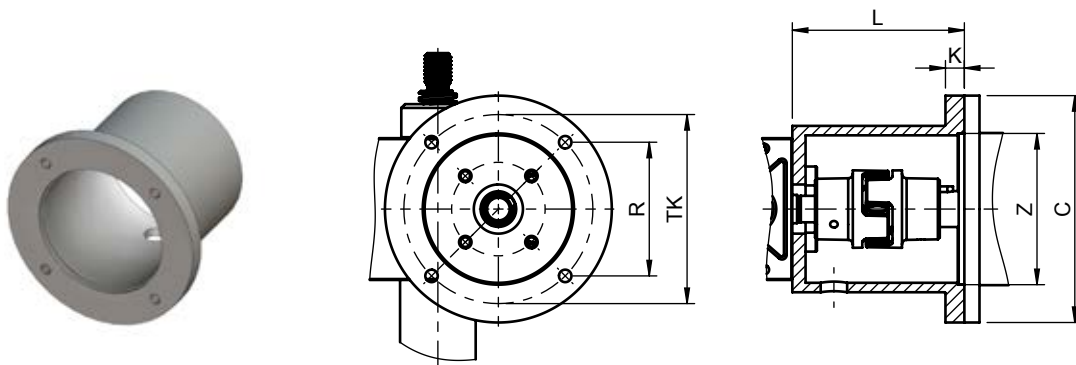
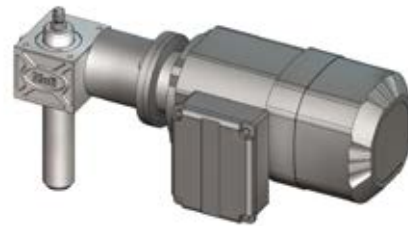

Dimensions									
Size	Motor	Type MG/ZF <sup>1)</sup>	Dimensions [mm]						cpl. size cpl. material shore hardness (shaft-Ø Muli) / (shaft-Ø Motor) <sup>4)</sup>
			C	TK	Z	L	R	K	
MULI 0	71	MG	120	100	80	66	70,7	10	RA14 AL-H 92 (1.0-Ø9x11) / (1.0-Ø14x11)
	80					RA14 AL-H 92 (1.0-Ø9x11) / (1.0-Ø19x11)			
MULI 1	71	MG	120	100	80	80	70,7	10	RA19 AL-D 92 (1.0-Ø10x25) / (1.0-Ø14x25)
	80					RA19 AL-D 92 (1.0-Ø10x25) / (1.0-Ø19x25)			
MULI 2	71	MG	120	100	80	80	70,7	10	RA19 AL-D 92 (1.0-Ø14x25) / (1.0-Ø14x25)
	80					RA19 AL-D 92 (1.0-Ø14x25) / (1.0-Ø19x25)			
	90					RA24 AL-D 92 (1.0-Ø14x30) / (1.0-Ø24x30)			
MULI 3	71	MG	120	100	80	90	70,7	10	RA19 AL-D 92 (1.0-Ø16x25) / (1.0-Ø14x25)
	80					RA19 AL-D 92 (1.0-Ø16x25) / (1.0-Ø19x25)			
	90					RA24 AL-D 92 (1.0-Ø16x30) / (1.0-Ø24x30)			
	100 / 112	MG + ZF	200	165	130	131	116,7	29	RA28 AL-D 92 (1.0-Ø16x35) / (1.0-Ø28x35)
MULI 4	80	MG	120	100	80	103	70,7	12	RA24 AL-D 92 (1.0-Ø20x30) / (1.0-Ø19x30)
	90		160	130	110	116	92	15	RA24 AL-D 92 (1.0-Ø20x30) / (1.0-Ø24x30)
	100 / 112	MG + ZF	200	165	130	131	116,7	29	RA28 AL-D 92 (1.0-Ø20x35) / (1.0-Ø28x35)
MULI 5	90	MG	160	130	110	136	92	15	RA28 AL-D 92 (1.0-Ø25x35) / (1.0-Ø24x35)
	100 / 112		200	165	130	152	116,7	16	RA28 AL-D 92 (1.0-Ø25x35) / (1.0-Ø28x35)

<sup>1)</sup> MG = Motor adapter flange / ZF = Intermediate flange.  
<sup>2)</sup> When ordering, please specify the diameter for connecting the coupling half shell to the motor shaft.  
<sup>3)</sup> Table show standard range. Custom motor adapter flanges upon request. Design and dimensions may change.  
<sup>4)</sup> Standard is coupling version 1.0 with key, spider made of polyurethane in hardness Shore A 92 (yellow).

# Drive Technology

## Motor adapter flanges MG for 3-servo motors

Motor adapter flanges are used to mount motors to worm gear screw jacks and house the coupling for connecting the motor to the drive shaft. When ordering, please specify the side to which the motor adapter flange is to be attached (A or B).

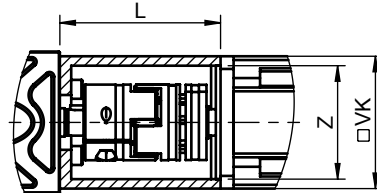
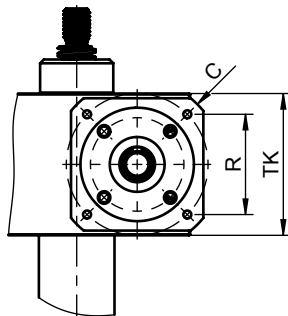

Dimensions									
Size	Motor	Type MG/ZF <sup>1)</sup>	Dimensions [mm]						cpl. size cpl. material shore hardness (shaft-Ø Muli) / (shaft-Ø Motor) <sup>4)</sup>
			VK	C	TK	Z	L	R	
MULI 0	AKM2	MG	58	70	63	40	60	44,5	AGS14 98 (2.1AL-Ø9x11) / (6.0ST-Ø9x18.5)
MULI 1	AKM2	MG	58	80	63	40	57	44,5	AGS14 98 (2.1AL-Ø10x11) / (6.0ST-Ø9x18.5)
	AKM3		70	90	75	60	70	53	AGS19 98 (2.1AL-Ø10x25) / (6.0ST-Ø14x25)
MULI 2	AKM2	MG	58	80	63	40	61	44,5	AGS14 98 (2.1AL-Ø14x11) / (6.0ST-Ø9x18.5)
	AKM3		70	90	75	60	85	53	AGS19 98 (2.1AL-Ø14x25) / (6.0ST-Ø14x25)
	AKM4		84	110	100	80	84	70,7	AGS19 98 (2.1AL-Ø14x25) / (6.0ST-Ø19x25)
MULI 3	AKM3	MG	70	90	75	60	91	53	AGS19 98 (2.1AL-Ø16x25) / (6.0ST-Ø14x25)
	AKM4		84	110	100	80	101	70,7	AGS19 98 (2.1AL-Ø16x25) / (6.0ST-Ø19x25)
MULI 4	AKM4	MG	84	110	100	80	104	70,7	AGS19 98 (2.1AL-Ø20x25) / (6.0ST-Ø19x25)
	AKM5		112	150	130	110	116	91,9	AGS24 98 (2.6AL-Ø20x30) / (6.0ST-Ø24x30)
MULI 5	AKM5	MG	112	150	130	110	136	91,9	AGS24 98 (2.6AL-Ø25x30) / (6.0ST-Ø24x30)
	AKM6		138	180	165	130	145	116,7	AGS28 98 (2.6AL-Ø25x35) / (6.0ST-Ø32x35)
	AKM7		188	230	215	180	168	152	AGS28 98 (2.6AL-Ø25x35) / (6.0ST-Ø38x35)

<sup>1)</sup> MG = Motor adapter flange / ZF = Intermediate flange.

<sup>2)</sup> When ordering, please specify the diameter for connecting the coupling half shell to the motor shaft.

<sup>3)</sup> Table shows standard range. Custom motor adapter flanges upon request. Design and dimensions may change.

<sup>4)</sup> Standard is coupling version 2.1AL = 1 slot with key / 2.6AL = 2 slots with key / 6.0ST = tension ring, spider made of polyurethane in hardness Shore A 98 (red).



# Drive Technology

## Couplings RA and RG type 1.0 and 1.0a

Flexible couplings transmit the torque by positive locking, and compensate for slight non-alignment, stagger and offset of shafts. Standard spider 92 Shore A (AGS = 98 Shore A).

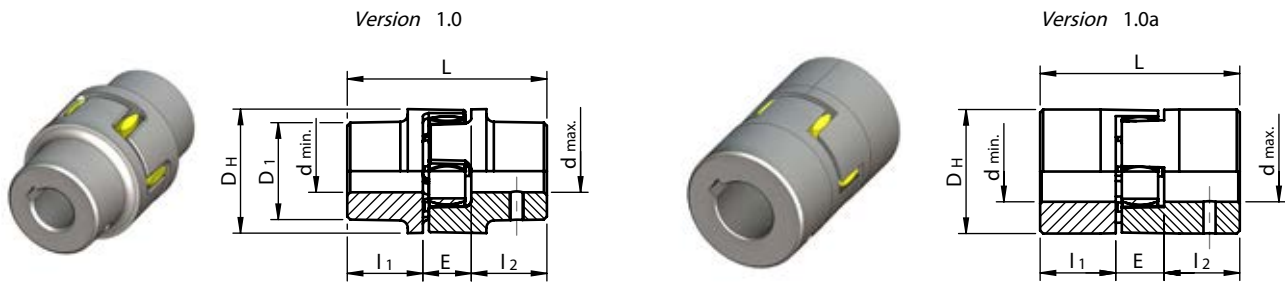

## Technical Data

### AL-D

Size	Type <sup>1)</sup>	Nominal torque [Nm]			Dimensions [mm]						
		92 Sh A <sup>2)</sup>	98 Sh A <sup>3)</sup>	64 Sh A <sup>3)</sup>	d <sub>min.</sub>	d <sub>max.</sub>	L	I <sub>1</sub> , I <sub>2</sub>	E	D <sub>H</sub>	D <sub>1</sub>
RA 14	1.0a	7,5	12,5	–	6	16	35	11	13	30	30
RA 19	1.0	10	17	–	6	19	66	25	16	41	32
	1.0a				19	24					41
RA 24	1.0	35	60	–	9	24	78	30	18	56	40
	1.0a				22	28					56
RA 28	1.0	95	160	–	10	28	90	35	20	66	48
	1.0a				28	38					66

### GG-25

RG 38	1.0	190	325	405	12	40	114	45	24	80	66
	1.0a				38	48					78
RG 42	1.0	265	450	560	14	45	126	50	26	95	75
	1.0a				42	55					94
RG 48	1.0	310	525	655	15	52	140	56	28	105	85
	1.0a				48	62					104
RG 55	1.0	410	685	825	20	60	160	65	30	120	98
	1.0a				55	74					118
RG 65	1.0	625	940	1175	22	70	185	75	35	135	115
	1.0a				65	80					135
RG 75	1.0	1280	1920	2400	30	80	210	85	40	160	135
	1.0a				75	95					160
RG 90	1.0	2400	3600	4500	40	97	245	100	45	200	160
	1.0a				90	110					200

<sup>1)</sup> 1.0 with key and locking screw / 1.0a big half shell with key and locking screw.

<sup>2)</sup> Standard spider made of polyurethane in hardness Shore A 92 (yellow).

<sup>3)</sup> exchangeable spider made of polyurethane in hardness Shore A 98 (red) & 64 (green).

<sup>4)</sup> Additional versions and sizes upon request.

# Drive Technology

## Couplings ASG type 2.1AL/2.6AL - 6.0ST

Flexible couplings transmit the torque by positive locking, and compensate for slight non-alignment, stagger and offset of shafts. Standard spider 92 Shore A (AGS = 98 Shore A).

Version 2.1/2.6 - 6.0

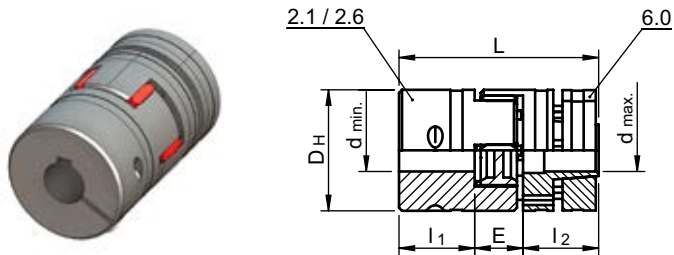

Technical Data							
Size	Nominal torque [Nm]	Dimensions [mm]					
	98 Sh A	d <sub>min.</sub>	d <sub>max.</sub>	L	I <sub>1</sub> , I <sub>2</sub>	E	D <sub>H</sub>
AGS19	17	6	24	66	25	16	40
AGS24	60	8	28	78	30	18	55
AGS28	160	10	38	90	35	20	65
AGS38	325	12	45	114	45	24	80
AGS38	450	14	55	126	50	26	95
AGS42	525	15	62	140	56	28	105
AGS48	685	20	74	160	65	30	120

<sup>1)</sup> Standard spider made of polyurethane in hardness Shore A 98 (red).

<sup>2)</sup> Standard combination consisting of 2.1AL/2.6AL & 6.0ST.

<sup>3)</sup> Additional versions and sizes upon request.

# Drive Technology

## Coupling hubs

For various applications different hub versions are available for AGS couplings and joint shafts VWK. The designs are different in positive form-locking (with key) and frictionally engaged (backlash-free).

### For couplings RA/RG

#### Version 1.0 & 1.0a

Hub with keyway and fixing screw. Positive power transmission; permissible torque depends on the permissible surface pressure. Not suitable for backlash-free power transmission for heavily reversing operation.



### For couplings AGS

#### Version 2.0

Clamping hub single-slotted without keyway. Frictionally engaged, backlash-free shaft-hub-connection. Transmittable torques depend on the bore diameter. Version 2.0 is standard for sizes until 14.



#### Version 2.1

Clamping hub single-slotted with keyway. Positive power transmission with additional frictional tightness. The frictional tightness avoids or reduces reversal backlash. Surface pressure on the keyway connection is reduced. Version 2.1 is standard for sizes until 14.



#### Version 2.5

Clamping hub twice-slotted without keyway. Frictionally engaged, backlash-free shaft-hub-connection. Transmittable torques depend on the bore diameter. Version 2.5 is standard for sizes starting from 19.



#### Version 2.6

Clamping hub twice-slotted with keyway. Positive power transmission with additional frictional tightness. The frictional tightness avoids or reduces reversal backlash. Surface pressure on the keyway connection is reduced. Version 2.6 is standard for sizes starting from 19.



#### Version 6.0

Clamping ring hub. Integrated frictionally engaged shaft-hub-connection for transmission of higher torques. Screw fitting on elastomer side. For details about torques and dimensions see on page 66. Suitable for high revolution speeds.



## Drive Technology

### For joint shafts VWK

#### Version 7.5

Hub connection with half shell without key. Frictionally engaged, backlash-free shaft-hub-connection for radial mounting. Transmittable torques depend on the bore diameter.

#### Version 7.6

Hub connection with half shell with key. Positive form locking shaft-hub-connection with additional frictional tightness for radial mounting. The frictional tightness avoids or reduces reversal backlash. Transmittable torques depend on the bore diameter.



## Drive Technology

### Offsets Couplings

In the case of the standard and large hubs RA14 – 48, the tapped hole G for the locking screw is located opposite the groove. Locking screws according to DIN 916 with toothed washer.

*Axial offsets  $K_a$*

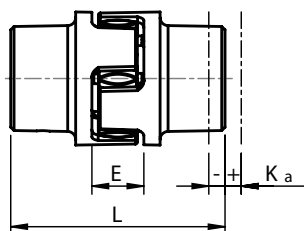

$$L_{\max} = L + K_a$$

*Radial offsets  $K_r$*

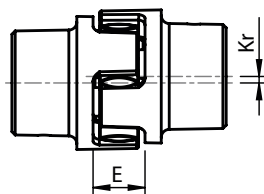

*Angel offsets  $K_w$*

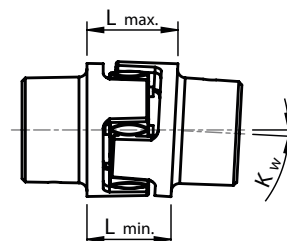

$$K_w [\text{mm}] = L_{\max} + L_{\min}$$

Technical Data											
Size	14	19	24	28	38	42	48	55	65	75	90
Max. axial displacement $K_a$ [mm]	-0,5	-0,5	-0,5	-0,7	-0,7	-1,0	-1,0	-1,0	-1,0	-1,5	-1,5
	1,0	1,2	1,4	1,5	1,8	2,0	2,1	2,2	2,6	3,0	3,4
Max. radial offset at n=1500 RPM $K_r$ [mm]	0,17	0,20	0,22	0,25	0,28	0,32	0,36	0,38	0,42	0,48	0,50
Max. angle offset at n=1500 RPM $K_w$ [°]	1,2	1,2	0,9	0,9	1	1	1,1	1,1	1,2	1,2	1,2
$K_w$ [mm]	0,67	0,82	0,85	1,05	1,35	1,70	2,00	2,30	2,70	3,30	4,30

# Drive Technology

## Joint shafts VWK

Easy radial mounting with 2-part coupling hubs, replacement of toothed spiders without displacement of the drive shafts. Lengths up to 4 meters are possible without pillow block bearing are possible depending on revolution speed and size. Low mass moment of inertia due to aluminum material. Combination with other hub versions are possible. Bore size to ISO-fit H7, key to DIN 6885 Bl. 1 – JS9.

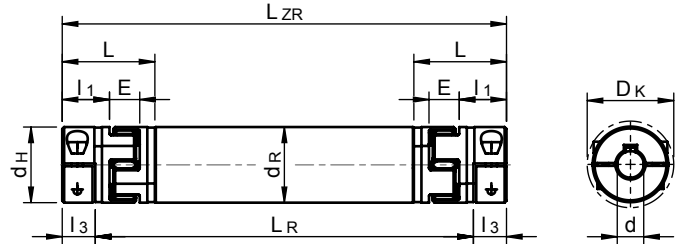

Technical Data																
Size	Nominal torque [Nm]		Dimensions [mm]													
	98 Sh A		$d_{min.}$	$d_{max.}$	$L_R min.$	$L_R max.$	$L_{ZR min.}$	$L_{ZR max.}$	$D_H$	$d_R$	$I_1$	$I_3$	L	E	$D_K$	C
VWK-ZR3-AGS19	21		8	20	98	2965	133	3000	40	40	25	17,5	49	16	46	5
VWK-ZR3-AGS24	60		10	28	113	3456	157	3500	55	50	30	22	59	18	57,5	5
VWK-ZR3-AGS28	160		14	38	131	3950	181	4000	65	60	35	25	67	20	73	5
VWK-ZR3-AGS38	325		18	45	163	3934	229	4000	80	70	45	33	83,5	24	83,5	5
VWK-ZR3-AGS42	450		22	50	180	3927	253	4000	95	80	50	36,5	93	26	93,5	5
VWK-ZR3-AGS48	525		22	55	202	3921	281	4000	105	100	56	39,5	103	28	105	5

<sup>1)</sup> Standard design 7.6 split clamping hub with key.  
<sup>2)</sup> Additional hub designs upon request.

### Example of order code

VWK-ZR3-AGS19-L<sub>R</sub>1000-7.6-Ø14m.N./7.5-Ø20o.N.

AGS19 = size

L<sub>R</sub> = 1000 mm (L<sub>R</sub> = distance between the drive shafts – C)

7.6-Ø14m.N. = hub type 7.6 with Ø14 mm hole with keyway

7.5-Ø20o.N. = hub type 7.5 with Ø20 mm hole without keyway

## Drive Technology

### Length calculation for joint shafts VWK without pillow block bearing

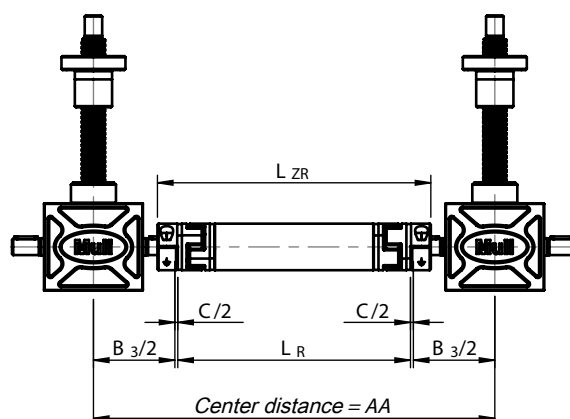
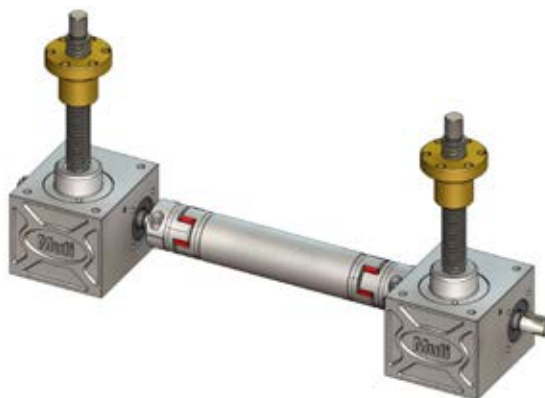

$$L_R = AA - B_3 - C$$

$L_R$  = Distance between the drive shafts

AA = Centre distance

$B_3$  = Width of screw jack

C = Mounting tolerance

# Drive Technology

## Length calculation for joint shafts VWK with pillow block bearing

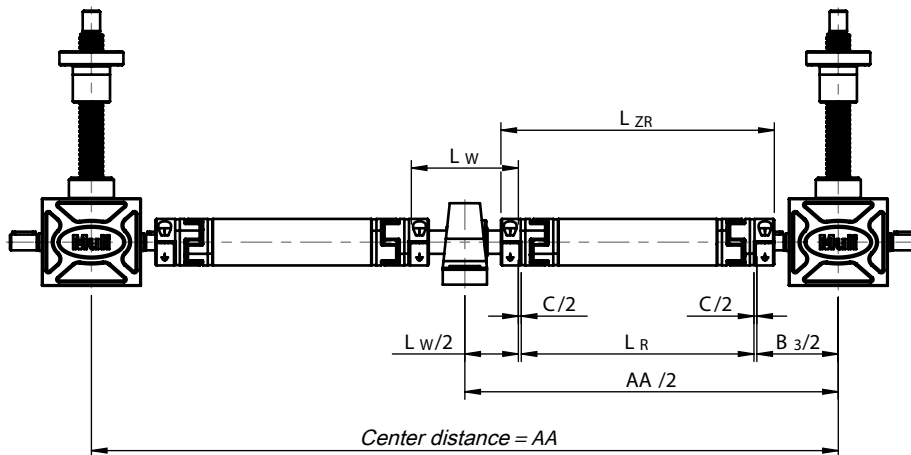
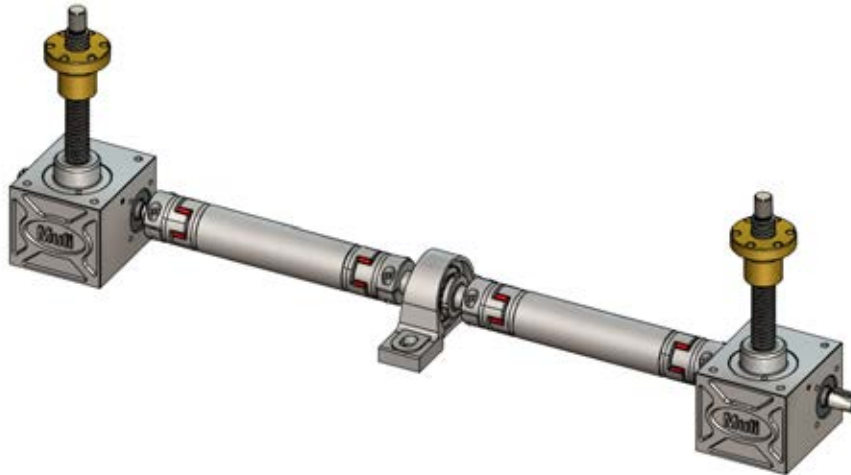

$$L_R = AA/2 - B_3/2 - L_W/2 - C$$

$L_R$  = Distance between the drive shafts

$AA$  = Centre distance

$B_3$  = Width of screw jack

$C$  = Mounting tolerance

$L_W$  = Length of intermediate shaft WZK



# Drive Technology

## Critical revolution speed for joint shafts VWK

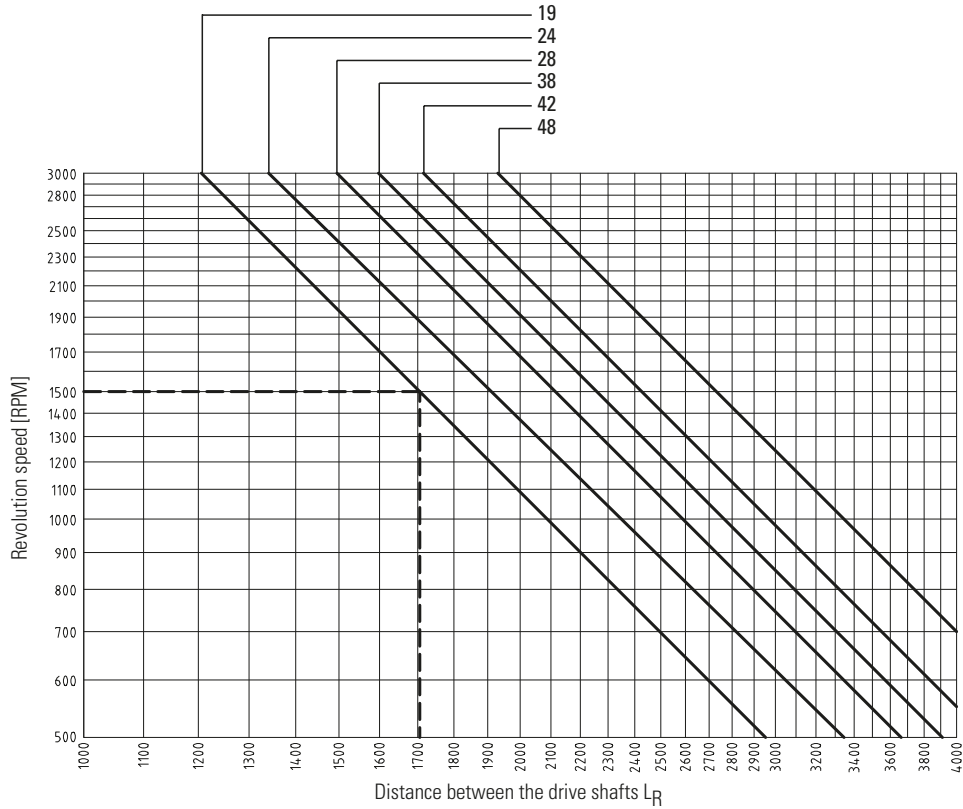

## Offsets tolerances for VWK joint shafts

Axial offsets  $K_a$

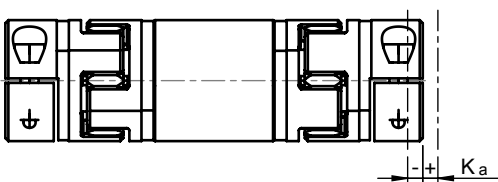

Radial offsets  $K_r$

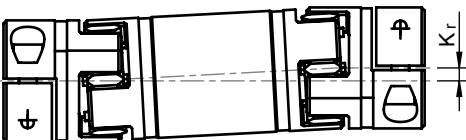

$$K_r [\text{mm}] = (L_{ZR} - 2x l_1 - E) \times \tan \alpha$$

Angular offsets  $K_w$

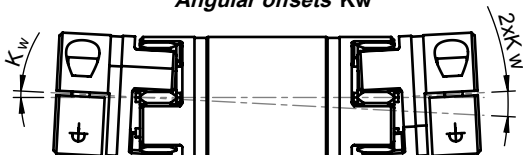

Offset Data

Size	Axial $K_a$ [mm]	Radial $K_r$ <sup>1)</sup> [mm]	Angle $K_w$ [°]
14	1,0	15,16	0,9°
	-1,0		
19	1,2	14,67	0,9°
	-1,0		
24	1,4	14,48	0,9°
	-1,0		
28	1,5	14,30	0,9°
	-1,4		
38	1,8	13,92	0,9°
	-1,4		
42	2,0	13,73	0,9°
	-2,0		
48	2,1	13,51	0,9°
	-2,0		
55	2,2	13,19	0,9°
	-2,0		
65	2,6	12,80	0,9°
	-2,0		

<sup>1)</sup> Radial offset referring to a shaft length  $L_{ZR} = 1000\text{mm}$

# Drive Technology

## Pillow block bearing UKP

The standard range for case bearing with clamping bushing. Cast iron case with coated surface protected against corrosion. The bearing inserts made from roller bearing steel with forged rings which is positive for the life-time.

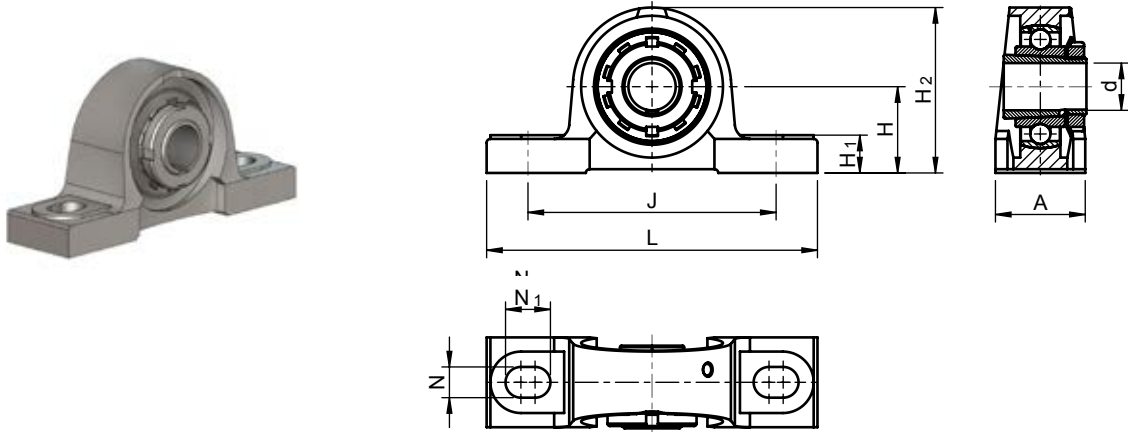

Technical Data												
Size	Pillow block bearing UKP	Joint shaft VWK	Intermediate shaft pin WZK	Dimensions [mm]								
				d	L	A	H	H <sub>1</sub>	H <sub>2</sub>	J	N	N <sub>1</sub>
MULI 0	UKP205	ZR3-AGS19	WZK-20/92-OP <sup>1) 2) 3)</sup>	20	140	38	36,5	16	70	105	13	19
MULI 1												
MULI 2												
MULI 3		ZR3-AGS24										
MULI 2												
MULI 3												
MULI 4	UKP207	ZR3-AGS28	WZK-30/124-OP <sup>1) 2) 3)</sup>	30	167	48	47,6	19	94	127	17	21
MULI 5												
MULI 4												
MULI 5		ZR3-AGS38										
JUMBO 1												
JUMBO 2/3												
JUMBO 1	UKP211	ZR3-AGS42	WZK-50/150-OP <sup>1) 2) 3)</sup>	50	219	60	63,5	22	126	171	20	25
JUMBO 2/3												
JUMBO 4												
JUMBO 5		ZR3-AGS48										
JUMBO 4												
JUMBO 5												

<sup>1)</sup> 01) OP = without key (standard), 1P = key on one side, 2P = key on both sides

<sup>2)</sup> The above mentioned values for LW are standard valid for joint shafts type VWK. Depending on the application this value may be different.

<sup>3)</sup> WZK-Ød/L<sub>w</sub>\*P

## Intermediate shaft pin WZK

Standard version without key in combination with pillow block bearing UKP and joint shaft VWK. Different versions with one key or keys on both sides upon request.

Material: 1.2210.

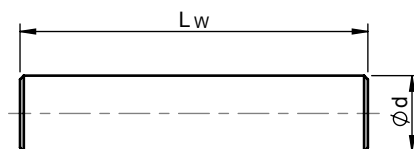

# Drive Technology

## Joint shafts VW

The VW connecting shafts series are rigid shafts with a key way at each end. For greater distances and diameters of axle, some of these shafts are available as tubular shafts.

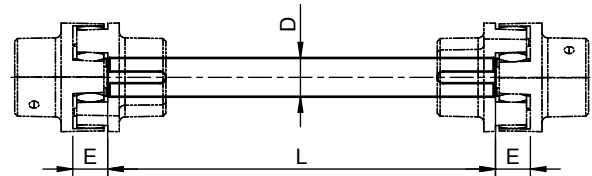

Technical Data		
Size	Dimensions [mm]	Combined with Couplings size / type / nominal torque [Nm]
VW20	20	RA19-1.0a / 10 & RA24-1.0 / 35
VW25	25	RA24-1.0a / 35 & RA28-1.0 / 95
VW30	30	RA28-1.0a / 95 & RG38-1.0 / 190
VW35	35	RG38-1.0 / 190 & RG42-1.0 / 265
VW40	40	RG42-1.0 / 265 & RG48-1.0 / 310
VW45	45	RA48-1.0 / 310 & RG55-1.0 / 410
VW50	50	RG55-1.0 / 410 & RG65-1.0 / 625

### Length calculation for joint shaft VW

$$L = AA - B_3 - 2xE$$

- L = Length of joint shaft
- AA = Centre distance
- B<sub>3</sub> = Width of screw jack
- E = Coupling dimensions ( page 65 )

### Example of order code

VW20-RA19-L1000-1.0-Ø10-1.0-Ø14

Size: 20  
 Length of joint shaft: L  
 Coupling half shell type 1.0 with key

### Critical speed for VW joint shafts

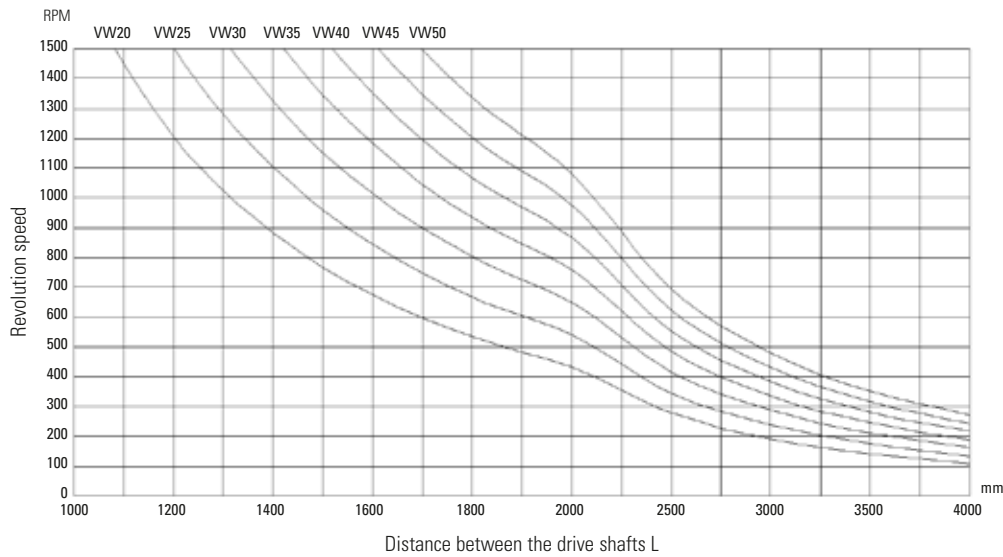

# Drive Technology

## Joint shafts GX

Torsionally stiff shafts suitable for connection of screw jacks. Noise, rotation vibrations and shocks are dampened and compensation of axial and radial displacements. Additionally the shafts are oil resistant and withstand high temperatures. Suitable for long connection distances and/or high revolution speeds. Flexible shafts are maintenance-free. By removing the axial screws, the shaft can easily be removed and disconnected without displacement of the drive shafts. The shafts will be delivered as tubes with couplings mounted on both sides (length L according to customer information). For very long distances pillow block bearings are required. For the perfect alignment we recommend the usage of joint shafts with clamping units.

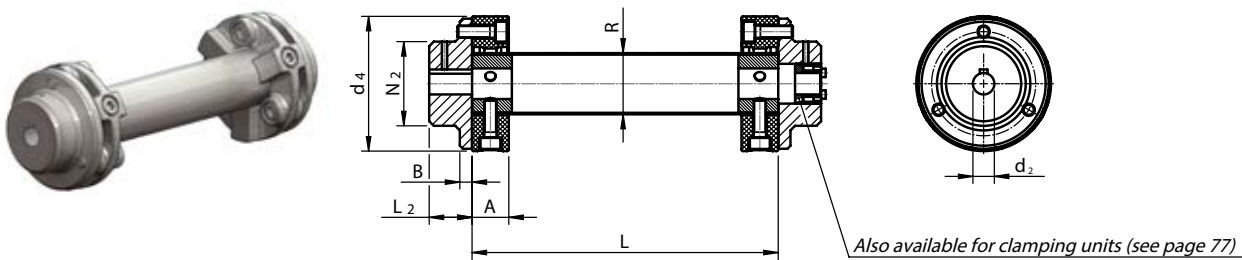

Technical Data												
Size	M <sup>1)</sup> [Nm]	Dimensions [mm]									Weight	
		d <sub>2 min.</sub>	d <sub>2 max.</sub>	A	B	C	R	d <sub>4</sub>	L <sub>2</sub>	N <sub>2</sub>	m <sub>1</sub> <sup>2)</sup> [kg]	m <sub>2</sub> <sup>3)</sup> [kg/m]
GX1	10	10	25	18	7	5	30	56	24	36	0,47	1,05
GX2	30	14	38	24	8	5	40	88	28	55	1,06	1,42
GX4	60	16	45	25	8	5	45	100	30	65	2,31	1,61
GX8	120	20	55	30	10	5	60	125	42	80	3,55	2,16
GX16	240	22	70	35	12	5	70	155	50	100	6,16	2,53
GX25	370	22	85	40	14	5	85	175	55	115	9,5	3,09
GX30	550	28	100	50	16	5	100	205	66	140	15,21	3,64

<sup>1)</sup> Transmissible torque <sup>2)</sup> m<sub>1</sub> = Weight without middle part <sup>3)</sup> m<sub>2</sub> = Weigth of middle piece per meter.

### Example of order code

GX8-1000-25H7-1-25H7-1

Size: GX8

Distance between the drive shafts: L (1000mm)

1. First hub bore with key Ø25-1 (without key Ø25-0)
2. Second hub bore with key Ø25-1 (without key Ø25-0)

### Length calculation for joint shaft GX

$$L = AA - B_3 - C$$

- L = Distance between the drive shafts
- AA = Centre distance
- B<sub>3</sub> = Width of screw jack
- C = Mounting tolerance

### Critical speed for GX joint shafts

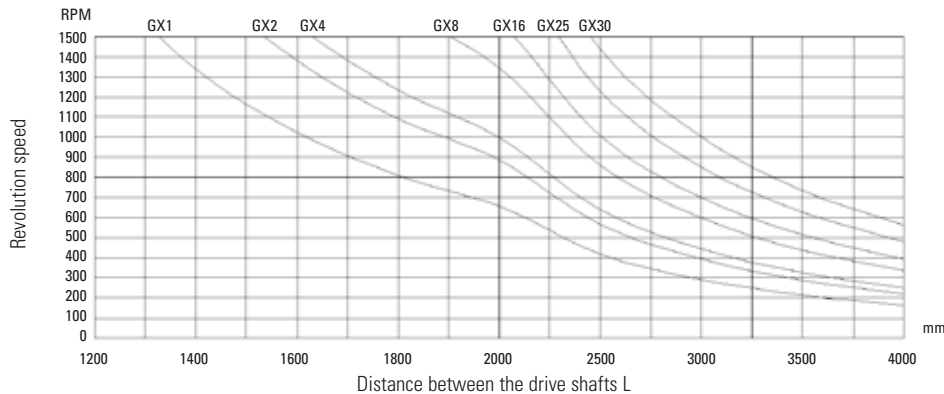

## Drive Technology

### Clamping units

Perfect tension distribution between shaft and hub makes assembly / disassembly easy with standard tools. Perfect for screw jacks with changing load impacts e.g. when accelerating and braking. Self-centering with good concentricity between shaft and hub. Sufficient tolerances of shaft and hub  $h9/H9$ .

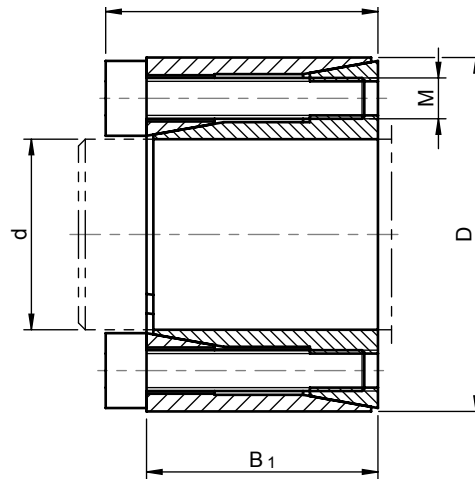

### Technical Data

Size	Dimensions [mm]			Clamping screws DIN EN ISO 4762 – 12.9 $\mu$ ges. = 0,14			Transmittable torque or axial force		Surface pressure between the clamping unit	
	d x D	B	B <sub>1</sub>	M	z Quantity	TA [Nm] <sup>1)</sup>	T [Nm]	F <sub>ax</sub> [kN]	PW [N/mm <sup>3</sup> ]	PN [N/mm <sup>3</sup> ]
MULI 0	9 x 20	15,5	13	M2,5	4	1,2	16	3	121	54
MULI 1	10 x 20	15,5	13	M2,5	4	1,2	17	3	109	54
MULI 2	14 x 26	20	17	M3	4	2,2	40	6	97	52
MULI 3	16 x 32	21	17	M4	4	4,9	80	10	149	74
MULI 4	20 x 38	26	21	M5	4	10	164	16	155	82
MULI 5	25 x 47	32	26	M6	4	17	289	23	140	75
JUMBO 1	25 x 47	32	26	M6	4	17	289	23	140	75
JUMBO 2	30 x 55	32	26	M6	6	17	520	35	175	96
JUMBO 3	30 x 55	32	26	M6	6	17	520	35	175	96
JUMBO 4	35 x 60	37	31	M6	8	17	810	46	173	101
JUMBO 5	48 x 80	44	36	M8	8	41	2052	85	198	119

<sup>1)</sup> Max. tightening torques of the screws. These can be reduced to max. 40% of the above mentioned values. T, T<sub>ax</sub>, P<sub>W</sub> and P<sub>N</sub> are decreasing proportionally.

# Drive Technology

## Bevel gear boxes KRG

The spiral bevel gear boxes offer numerous advantages to the designer and have been specially selected to complement the Thomson range of worm gear screw jacks and accessories. The gear boxes are fully machined with tapped holes for universal mounting, thus offering six possible mounting positions.

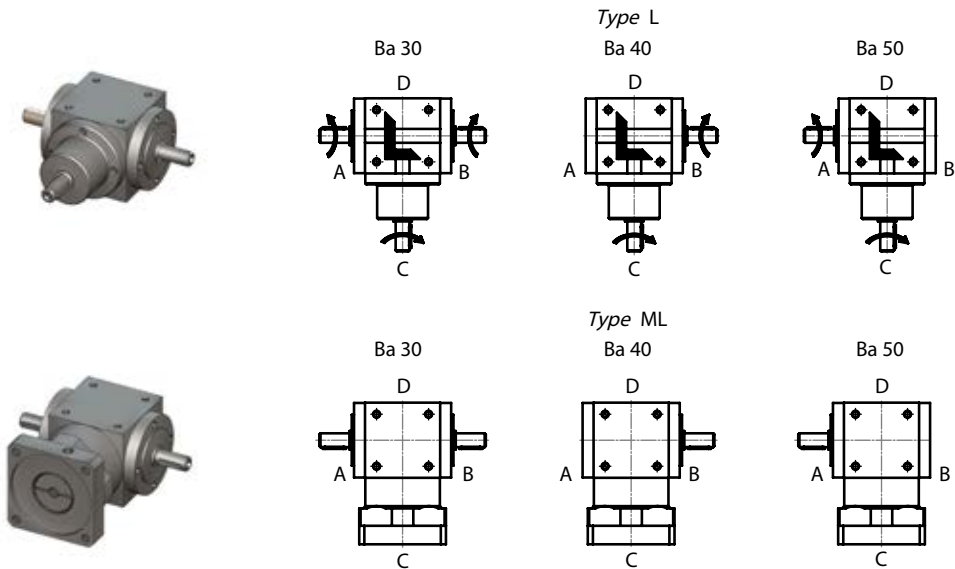

Technical Data			
Mechanical efficiency $\eta$	Gear size		
	50	100 – 230	250 – 400
At nominal moment	$0.85 \leq \eta \leq 0.9$	$0.9 \leq \eta \leq 0.94$	$0.95 \leq \eta \leq 0.96$

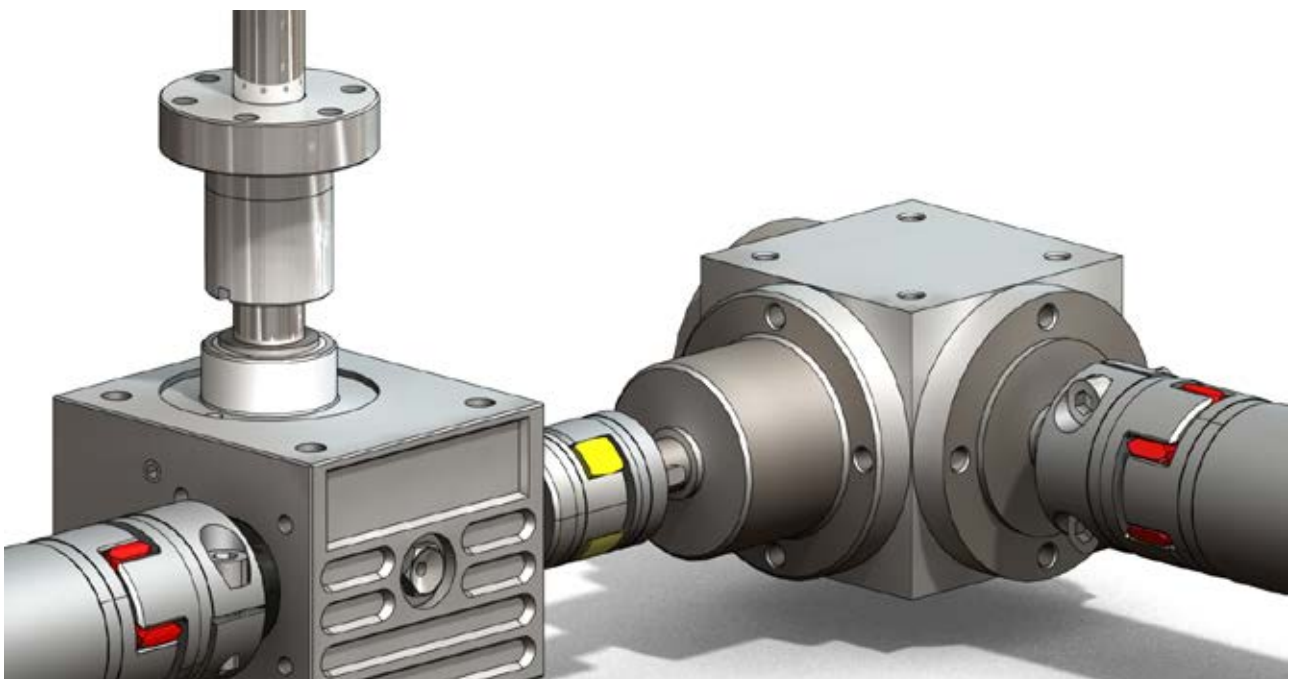

# Drive Technology

## Bevel gear boxes KRG - general specifications

### Version

Cube

- sizes 50, 100, 200 without lubrication fittings
- please advise mounting position (base side) starting from size 230
- please advise mounting position (base side) and position of lubrication fittings starting from size 250

### Material

Lamellar graphite cast iron EN-GJL-250 (0.6025) or spherical graphite cast iron ENGJS-400-15 (0.7040) or G-Al Si 10 Mg (0.1645).

### Shaft

Shaft centring according to DIN 332 Sheet 2, feather key according to DIN 6885, Sheet 1. Tolerance j6 or k6. Material: C 45 (1.0503) or 42 Cr Mo 4 (1.7225)

Hollow shafts with keyway or smooth, with shrink-fit washer. Tolerance Hole H7. Material: C 45 (1.0503)

### Bevel gears

Klingelberg Palloid or Klingelberg Zylo-Palloid spiral teeth, optimised tooth flanks and profile geometry, tooth flanks milled, hardened and lapped. Material: Stainless steel 16 Mn Cr 5 (1.7131) or 17 Cr Ni Mo 6 (1.6587)

### Shaft-hub connection

Non-positive or positive locking, parts are fitted warm.

### Shaft seal

With or without dust scraper according to DIN 3760.

Material: NBR, FPM/FKM

### Bearings

Conical roller bearings or roller bearings, depending on version.

### Lubricants

According to DIN 51502 mineral grease or oil, depending on revs.

### Installation position

Please specify when ordering.

### Volume

Depends on installation position, see Operating Instructions.

### Surface treatment

Nitro-cellulose base coat. Colour: RAL 7035 light grey.

### Noise

Approx. 75 dB(A) at 1m distance.

### Lifetime of bearings

Approx. 20,000 hours of operation.

### Max. permitted gear temperature

80 °C

Technical Data														
Ratio <sup>2)</sup>	Input speed $n_1$ [RPM]	Output speed $n_2$ [RPM]	Size 50		Size 100		Size 200		Size 230		Size 250		Size 300	
			P [kW]	Output torque $M_2$ [Nm]	P [kW]	Output torque $M_2$ [Nm]	P [kW]	Output torque $M_2$ [Nm]	P [kW]	Output torque $M_2$ [Nm]	P [kW]	Output torque $M_2$ [Nm]	P [kW]	Output torque $M_2$ [Nm]
i = 1,0	500	500	0,89	17	2,41	46	5,76	110	8,9	170	14,14	270	26,18	500
	1000	1000	1,68	16	4,4	42	9,42	90	15,71	150	23,04	220	42,93	410
	1500	1500	2,2	14	5,81	37	12,88	82	20,42	130	28,27	180	54,97	350
	3000	3000	3,14	10	8,8	28	18,85	60	28,27	90	10,84	130	69,11	220
i = 2,0	500	250	0,47	18	1,26	48	3,14	120	4,71	180	7,85	300	15,18	580
	1000	500	0,89	17	2,36	45	5,76	110	8,9	170	14,14	270	26,18	500
	1500	750	1,26	16	3,38	43	7,85	100	12,57	160	19,63	250	35,34	450
	3000	1500	2,2	14	5,81	37	12,88	82	20,42	130	28,27	180	54,97	350
i = 3,0	500	166,67	0,26	15	0,66	38	1,47	84	2,79	160	4,19	240	7,33	420
	1000	333,33	0,49	14	1,29	37	2,62	75	5,24	150	6,98	200	12,57	360
	1500	500	0,68	13	1,83	35	3,51	67	6,81	130	9,42	180	16,23	310
	3000	1000	1,15	11	2,93	28	5,45	52	10,47	100	15,71	150	25,13	240

<sup>1)</sup> The nominal torque may be exceeded by a factor of 1.8 for short period.

<sup>2)</sup> Additional sizes, types and gear ratios upon request.

# Drive Technology

## Bevel gear boxes KRG - dimensions for type L

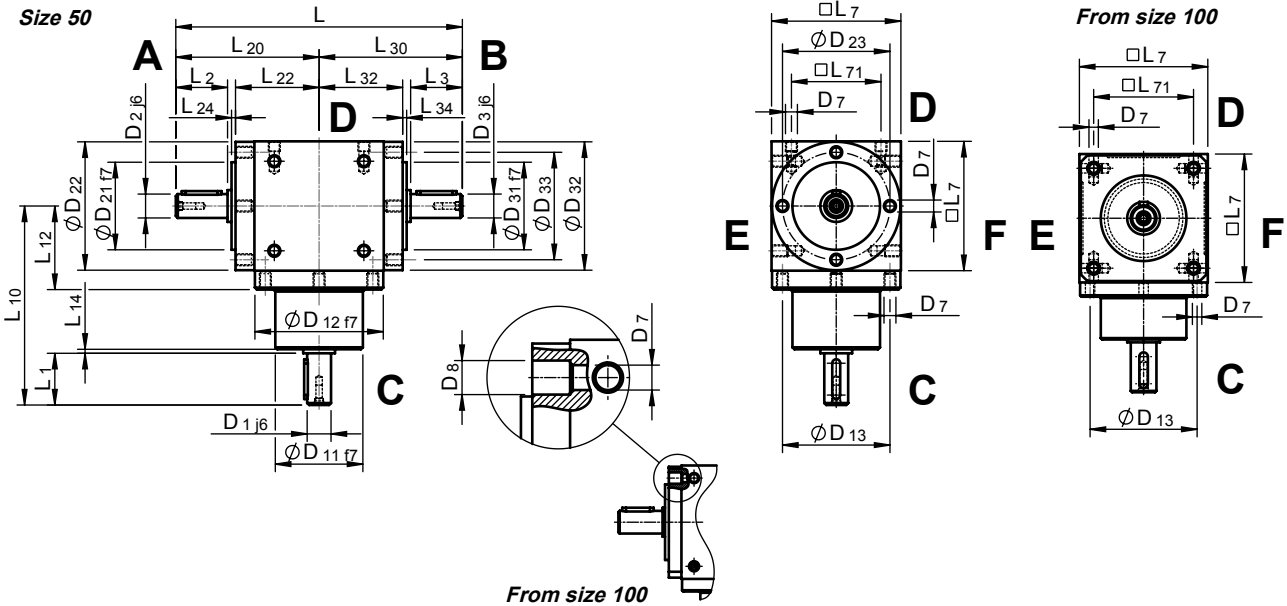

Dimensions											
Size	Ratio	Dimensions [mm]									
		D <sub>1</sub>	D <sub>2/3</sub>	D <sub>7</sub>	D <sub>8</sub>	D <sub>11</sub>	D <sub>12</sub>	D <sub>13</sub>	D <sub>21/31</sub>	D <sub>22/32</sub>	D <sub>23/33</sub>
50	1 - 2	12	12	M6	-	44	64,5	54	44	64,5	54
	3 + 4										
100	1 - 2	18	18	M8	9	60	89	75	60	-	-
	3 + 4	15									
200	1 - 2	25	25	M10	11	80	119	100	80	-	-
	3 + 4	20									
230	1 - 2	32	32	M10	11	95	135	115	100	-	-
	3 + 4	28									
250	1 - 2	35	35	M12	13,5	110	156	135	110	-	-
	3 + 4	28									
300	1 - 2	42	42	M12	13,5	120	198	175	120	-	-
	3 + 4	35									

Dimensions													
Size	Dimensions [mm]												
	L	L <sub>1</sub>	L <sub>2/3</sub>	L <sub>7</sub>	L <sub>10</sub>	L <sub>12</sub>	L <sub>14</sub>	L <sub>20/30</sub>	L <sub>22/32</sub>	L <sub>24/34</sub>	L <sub>71</sub>	Key D <sub>1</sub>	Key D <sub>2</sub> +D <sub>3</sub>
50	144	26	26	65	100	42	2	72	42	2	45	4x4x20	4x4x20
					115								
100	190	35	35	90	122	55	2	95	55	2	70	6x6x25	6x6x25
		30			127								
200	244	45	45	120	162	75	2	122	72	3	100	8x7x36	8x7x36
		40			157								
230	274	60	50	140	180	83	2	137	82	3	110	10x8x45	10x8x45
		55			195								
250	320	60	60	160	212	95	2	160	95	3	120	10x8x45	10x8x45
		55			227								
300	406	80	80	200	273	120	3	203	117	3	160	12x8x60	12x8x60
		68			261								

<sup>1)</sup> Additional sizes, types and gear ratios upon request.



# Drive Technology

## Bevel gear boxes KRG - dimensions for type ML

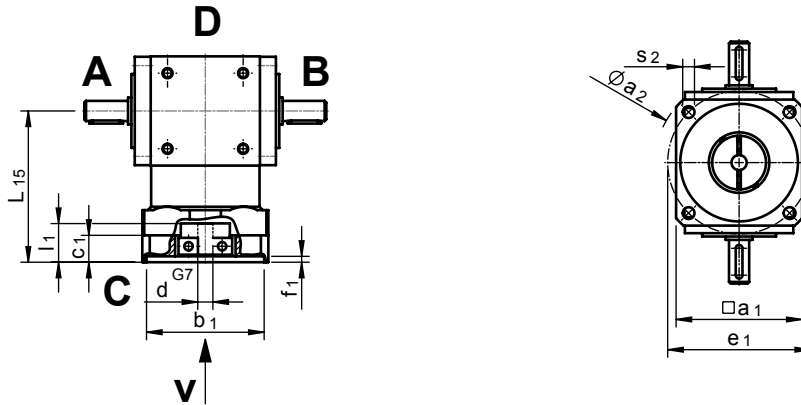

Dimensions											
Size	Ratio	Dimensions [mm]									
		d	b <sub>1</sub>	e <sub>1</sub>	a <sub>1</sub>	a <sub>2</sub>	s <sub>2</sub>	l <sub>1</sub>	f <sub>1</sub>	c <sub>1</sub>	L <sub>15</sub>
50	1 – 4	9	70	85	75	100	4xØ7	20	4,5	16	90
		11	80	100	90	120		23			
		14	95	115	115	140	4xØ9	30			
100	1 – 6	9	70	85	95	105	4xØ7	20	4,5	16	125
		11	80	100		120		23			
		14	95	115	115	140	4xØ9	30			
		19	110	130	130	160		40			
200	1 – 6	11	80	100	125	140	4xØ7	23	5	25	145
		14	95	115			4xØ9	30			
		19	130	165	140	190	4xØ11	40			
		24						50			
		28						60			
230	1 – 6	19	95	115	-	145	4xØ9	40	5	12	215
		24	110	130				145		160	
		28	130	165	145	190	4xM12	60		18	
		32	180	215	200	250		60			
		38	230	265	242	300		80			
250	1 – 6	19	130	165	145	190	4xØ11	40	5	15	230
		24	130	165	-	200		50			
		28	180	215	200	250	4xM12	60		18	
		32	180	215	-	250		60			
		38	230	265	242	300		80		250	
300	1 – 6	28	180	215	200	250	4xM12	60	5	18	280
		32	180	215	-	250		60			
		38	230	265	242	300		80			
		42	250	300	260	350	4xM16	110	6	24	310
		48	250	300	-	350		110			

1) Additional sizes, types and gear ratios upon request.

# Installation and Maintenance

## Direction of rotation

Before starting installation work, the direction of rotation of all worm gear screw jacks, bevel gear boxes and the drive motor must be checked with regard to the feed direction of each individual worm gear screw jack.

## Alignment errors

All components must be carefully aligned during installation. Alignment errors and stresses increase power consumption and lead to overheating and premature wear. Before a drive unit is attached, each worm gear screw jack should be turned through its entire length by hand without load. Variations in the amount of force required and/or axial marks on the outside diameter of the screw indicate alignment errors between the worm gear screw jack and its additional guides. In this case, the relevant mounting bolts must be loosened and the worm gear screw jack turned through by hand again. If the amount of force required is now constant throughout, the appropriate components must be aligned. If not, the alignment error must be localized by loosening additional mounting bolts.

## Test run

The direction of rotation of the complete system and correct operation of the limit switches must be checked again before attaching the drive motor. In the case of version N (translating screw jack), check that the screw is lubricated with grease from the interior of the gear box and relubricate if necessary. In the case of version R (rotating screw jack), the jack screw should be coated with suitable grease to provide lubrication for lifting operation. The first test runs can then be carried out without load. A maximum operating time of 30 % can not be exceeded at trial runs under weight for worm gear screw jacks with trapezoidal screws.

## Operation

The loads, speeds and operating conditions specified for the worm gear screw jacks and transmission components must not be exceeded even briefly. Failure to observe this condition will invalidate all claims under guarantee.

## Safety

All mounting bolts must be retightened after a short period of operation. Under extreme operating conditions, the wear on the screw nut (worm gear) must be checked at shorter intervals, depending on the power-on time, by inspecting the play in the thread. The screw nut (worm gear) must be replaced if the axial backlash with a single-start thread is more than one-quarter of the thread pitch.

## Lubrication

The worm gear screw jacks are lubricated by the manufacturer and are ready for operation on delivery. The versions N/V must be lubricated via their grease nipples with one of the greases specified below at intervals of 30 – 50 operating hours. The screw should be cleaned and greased at the same time. We recommend that the gear box be cleaned to remove old grease and refilled with fresh grease after approx. 700 operating hours or 18 months. The worm gear screw jacks can be dismantled relatively easily:

- Remove the two threaded pins securing the bearing cover.
- Loosen the screw and remove the screw protection if necessary.
- Remove the bearing cover with the aid of a face spanner.

Please proceed as follows to refit the bearing cover. Mount the bearing cover with face spanner and check the operation performance of the worm wheel gear set. Too big force influences the easy movement for smaller screw jack sizes. When necessary the securing holes at the bearing cover have to be drilled again.

## Standard grease

Type: Lithogrease G 421

Manufacturer: Zeller + Gmelin, Aalen, Germany



## EUROPE

### United Kingdom

Thomson  
Office 9, The Barns  
Caddsdow Business Park  
Bideford, Devon, EX39 3BT  
Phone: +44 (0) 1271 334 500  
E-mail: sales.uk@thomsonlinear.com

### Germany

Thomson  
Nürtinger Straße 70  
72649 Wolfschlügen  
Phone: +49 (0) 7022 504 403  
Fax: +49 (0) 7022 504 405  
E-mail: sales.germany@thomsonlinear.com

### France

Thomson  
Phone: +33 (0) 243 50 03 30  
Fax: +33 (0) 243 50 03 39  
E-mail: sales.france@thomsonlinear.com

### Italy

Thomson  
Via per Cinisello 95/97  
20834 Nova Milanese (MB)  
Phone: +39 0362 366406  
Fax: +39 0362 276790  
E-mail: sales.italy@thomsonlinear.com

### Spain

Thomson  
E-mail: sales.esm@thomsonlinear.com

### Sweden

Thomson  
Estridsväg 10  
29109 Kristianstad  
Phone: +46 (0) 44 24 67 00  
Fax: +46 (0) 44 24 40 85  
E-mail: sales.scandinavia@thomsonlinear.com

## SOUTH AMERICA

### Brasil

Thomson  
Av. Tamboré, 1077  
Barueri, SP – 06460-000  
Phone: +55 11 4615-6470  
E-mail: sales.brasil@thomsonlinear.com

## USA, CANADA and MEXICO

Thomson  
203A West Rock Road  
Radford, VA 24141, USA  
Phone: 1-540-633-3549  
Fax: 1-540-633-0294  
E-mail: thomson@thomsonlinear.com  
Literature: literature.thomsonlinear.com

## ASIA

### Asia Pacific

Thomson  
E-mail: sales.apac@thomsonlinear.com

### China

Thomson  
Rm 2205, Scitech Tower  
22 Jianguomen Wai Street  
Beijing 100004  
Phone: +86 400 6661 802  
Fax: +86 10 6515 0263  
E-mail: sales.china@thomsonlinear.com

### India

Thomson  
c/o Fortive India Pvt. Ltd.  
Unit No. FF A 07  
Art Guild House, A Wing, 1st Floor, L.B.S Marg  
Kurla – West, Mumbai – 400070 India  
Phone: +91 22 6249 5043  
E-mail: sales.india@thomsonlinear.com

### Japan

Thomson  
Minami-Kaneden 2-12-23, Suita  
Osaka 564-0044 Japan  
Phone: +81-6-6386-8001  
Fax: +81-6-6386-5022  
E-mail: csjapan@scgap.com

### Korea

Thomson  
Hangangdaero 67 gil 7  
102 Bldg Rm 2602  
Yongsan-gu, Seoul – South Korea (04322)  
Phone: +82 10 3418 6920 / +82 10 8652 4970  
E-mail: sales.korea@thomsonlinear.com